



PROVIDING A BETTER CLIMATE ANYWHERE.

OWC3612-OWC3632-OWC3634 (QC)

Deluxe Portable Water-Cooled Cooler

ENGINEERING, INSTALLATION AND SERVICE MANUAL



*Water
Cooled*



OCEANAIRE-INC.COM

1731 Wall Street, Suite 100

Mount Prospect, IL 60056

Phone: (847) 583-0311

Fax: (847) 583-0312



Refrigerant
Safety Group
A2L

Table of Contents

GENERAL INFORMATION.....	3
PRODUCT DATA AND SPECIFICATIONS.....	4
<u>UNIT DESCRIPTION</u>	
Standard Features.....	5
Applications.....	6
Electrical Information.....	7
Unit Interior.....	9
Installation Instructions/Start Up Procedure.....	10
Optional Accessories.....	11
HK-Series Hose Kits.....	15
HK-Series Hose Kits Installation Instructions.....	16
HK-QC Series Hose Kits.....	17
HA-QC Series Hose Kits.....	19
<u>SERVICE</u>	
Thermostat / Controller Operation.....	20
Alarm / Error Codes.....	22
Water Valve.....	23
Preventive Maintenance.....	25
<u>DIAGRAMS</u>	
Three Phase Monitor.....	26
Piping Schematic.....	27
Wiring Diagrams.....	28
WARRANTY.....	31
ADDITIONAL SAFETY WARNINGS AND NOTICES.....	32
INFORMATION ON SERVICING.....	33

FORWARD

This manual provides the user with basic details for the installation and operation of the OceanAire OWC's spot coolers. It is recommended to read and fully understand the instructions outlined within this manual before operating the unit.



SAFETY WARNING

As with all air conditioning equipment, it is recommended to have the OWC sized and installed by a licensed specifying engineer and contractor in accordance with all local and state codes. The length of service received can be extended by following the installation and preventive maintenance instructions.

In our continuous pursuit of improvement, the items and procedures described in this manual are subject to change without notice. Please note Model and Serial number of the OWC unit when contacting the factory.

GENERAL INFORMATION

The OceanAire OWC model is a portable water-cooled air conditioner designed for permanent or temporary spot cooling applications. The entire air conditioning unit has been built in an attractive sheet metal cabinet, equipped with heavy-duty casters for mobility. All OWC models come with an LCDI power cord for electrical connection. These spot-coolers are designed to direct air to specific areas or objects through a discharge grille located on the upper-front of the unit.

The OWC is a self-contained unit with the entire cooling system (blower assembly, electrical, refrigerant, and water side components), neatly arranged in a gray and blue polyester powder coated metal cabinet. When connected to the proper source of electrical power, the OWC is controlled by a solid-state electronic device with numerous temperature and airflow controls to provide the desired level of comfort and cooling.

A wide variety of accessories and factory installed options are available for the OWC, allowing for improved performance and versatility.

WARRANTY
ALL OCEANAIRE PRODUCTS ARE COVERED BY THE OCEANAIRE
LIMITED WARRANTY
1 YEAR ON THE FULL PRODUCT
PLUS, 4 ADDITIONAL YEARS FOR THE COMPRESSOR
(Restrictions Apply)

WARRANTY CARD

It is important that the warranty card be filled out completely and returned to the factory within fourteen (14) days of the unit's installation in order to receive the benefits of the warranty.

NOTICE

NOT APPROVED FOR OUTDOOR USE

Unit will not operate at full capacity when run outdoors, and exposure to elements may result in immediate or premature component failure.

NOMENCLATURE

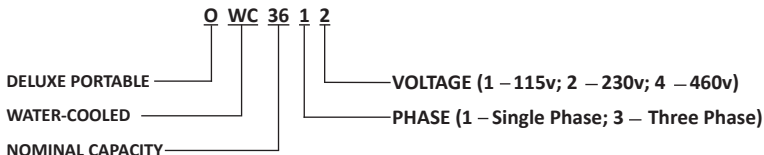

CAPACITY RATING

18.....	18,000 BTU/HR
24.....	24,000 BTU/HR
36.....	36,000 BTU/HR
60.....	60,000 BTU/HR

COOLING AMBIENT OPERATING RANGE

60° to 105°

SPECIFICATIONS

MODEL OWC	3612	3632	3634
COOLING CAPACITY	36,000	36,000	36,000
VOLTAGE (V/PHASE) AT 60Hz	208-230V - 1	208-230V - 3	460V - 3
AMPS	15.9	9.3	4.7
TOTAL WATTS	3307	3350	3744
IN-RUSH CURRENT	100	100	100
PLUG TYPE	6-20P LCDI	L15-20P	L16-20P
EER	13.4	13.4	13.4
COMPRESSOR	SCROLL	SCROLL	SCROLL
COMPRESSOR LRA	155	102.8	50
EVAP CFM - HIGH	1200	1200	1200
EVAP MOTOR AMPS	2	2	2
CONDENSER WATER FLOW			
AT 60F WATER IN (GPM)	2.2	2.2	2.2
AT 85F WATER IN (GPM)	9	9	9
WATER LINE CONNECTIONS			
WATER-IN BLACK LABEL	5/8"	5/8"	5/8"
WATER-OUT RED LABEL	5/8"	5/8"	5/8"
DRAIN YELLOW LABEL	3/8"	3/8"	3/8"
R-454b CHARGE (oz)	27	27	27
HEIGHT (INCH)	53.2	53.2	53.2
WIDTH (INCH)	28.1	28.1	28.1
DEPTH (INCH)	29.1	29.1	29.1
NET WEIGHT (lb)	335	335	365

SPECIFICATIONS SUBJECT TO CHANGE WITHOUT NOTICE

Notes:

- Cooling Capacity is total BTUH at 80°DB/67°WB return air, high fan speed, with 85°EWT and 95°LWT (9 GPM)
- Time delay fuses/circuit breakers are recommended
- EER is determined at High fan speed
- CFM with free discharge
- Amps and watts at 208/460 volts



*Water
Cooled*



STANDARD FEATURES

CABINET

The OWC cabinet is constructed of 18-gauge steel with a gray and blue polyester powder coated finish that will complement any decor. The entire cabinet is insulated with sound absorbing insulation for cool, quiet comfort. All units come equipped with swivel casters for portability and convenient set-up. For corrosion resistance all steel is either galvanized or powder coated.

DELUXE ELECTRONIC CONTROLLER

The OWC is equipped with a deluxe electronic controller. When proper power is connected to the unit, the thermostat will control the unit to cool a space to the desired temperature. The thermostat is also capable of controlling the fan to operate automatically (when needed) or continuously. To protect the compressor from short-cycling, there is a built-in time delay in the thermostat.

FAN SPEED CONTROL

With The deluxe electronic controller, you can set fan speed for manual or automatic. In manual mode setting, the fan speed can be set to any of the six fan speed levels, from 1 (Low) to 6 (High). In automatic setting, the controller will determine the best fan speed based on the interior temperature and selected SETPOINT. In the manual select fan speed mode, the fan speed may change automatically under certain conditions to protect the compressor.

CONDITION ALARM/ERROR

The deluxe electronic controller is constantly checking unit operation and component function. If the controller detects a fault in operation or with a component the display will show "ERR" and what type of error. See Alarm / Error table for list of error codes, system response and corrective action.

CONDENSATE PUMP

Each OWC unit comes equipped with an Automatic Condensate Pump that removes condensate. The pump discharges through a check valve located on top of the condensate pump assembly. The tubing exits through a 3/8 QC fitting, located in the recessed water connection area of the unit. The pump has capabilities up to a 20' lift, to handle almost any installation requirement. If a failure occurs with the operation of the pump circuit, the controller will display "FULL" + "TANK", illuminate the alarm icon and sound an alarm. When the failure has been corrected, or the condensate line blockage/kink has been resolved, the fault will clear, and the unit will resume operation.

HIGH PRESSURE SAFETY SWITCH

Located in the recessed area of the OWC unit is a manual reset high pressure switch. It is used for the protection of the compressor, in the event that the condenser water supply is turned off. If the internal pressure exceeds the limit setting, the switch cycles off the compressor, while the evaporator fan continues to operate. Once the water interruption has been resolved, turn the unit off. RESET THE RED BUTTON by pushing down on the red rubber boot, listen for a "click," and restart the unit.

FILTERS

The OWC unit is equipped with a washable filter at the air intake. The electrostatic mesh air filter is located behind the evaporator return air grille to filter the air before it is cooled, keeping the coil free from dust build-up. The filter can easily be removed and cleaned.

POWER CORD

The OWC unit is equipped with a ten-foot power cord for convenience.

APPLICATIONS

SPOT COOLER

The OWC can be used in an open environment to cool specific objects or “spots”. Spot Cooling is a convenient and economical way to provide air conditioning when cooling an entire space is not viable. Cool air is discharged from the unit’s grille and is directed where it is needed. A nozzle kit can be used to improve the air’s velocity.*

ROOM AIR CONDITIONER

The OWC operates as a room air conditioner because water is used as the means for heat rejection. The major advantage of water-cooled air conditioning is the convenience of connecting water hoses or lines, as opposed to the installation of condenser air ducts used for all air-cooled portables. A variety of hose kit lengths are available that can be connected to a water supply and drain, while providing portability within the conditioned space.

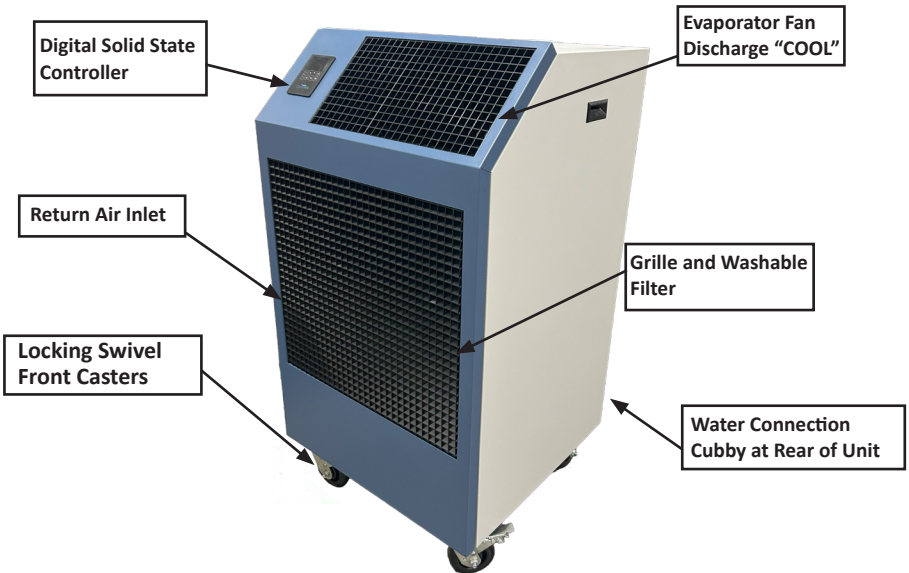

OWC36

*See OWC Optional Accessories section on pg. 11

ELECTRICAL CONFIGURATION







CAUTION

DO NOT USE THE LCDI AS AN ON/OFF SWITCH FOR THE UNIT. USING CORD AS ON/OFF SWITCH MAY RESULT IN DAMAGE TO THE UNIT/COMPONENTS OR PERSONAL INJURY.

WARNING

A DAMAGED LCDI POWER SUPPLY CORD MUST BE REPLACED WITH A NEW POWER SUPPLY CORD AND NOT REPAIRED. FAILURE TO REPLACE CORD MAY RESULT IN ELECTRICAL SHOCK LEADING TO INJURY OR DEATH.

All 3-phase models are equipped with locking plugs for added connection reliability. Refer to the chart below for plug and receptacle details for all OWC models.

UNIT/MODEL	PLUG CONFIGURATION	RECEPTACLE
<u>115 VOLT</u> OWC1811	 15A-125 VOLT NEMA 5-15P	NEMA 5-15R
<u>208-230 VOLT SINGLE PHASE</u> OWC2412 OWC3612	 20A-250 VOLT NEMA 6-20P	NEMA 6-20R
<u>208-230 VOLT SINGLE PHASE</u> OWC6012	 30A-250 VOLT NEMA 6-30P	NEMA 6-30R
<u>208-230 VOLT 3-PHASE</u> OWC3632	 20A-250 VOLT NEMA L15-20P	NEMA L15-20R
<u>208-230 VOLT 3-PHASE</u> OWC6032	 30A-250 VOLT NEMA L15-30P	NEMA L15-30R
<u>460 VOLT 3-PHASE</u> OWC3634 OWC6034	 20A-460 VOLT NEMA L16-20P	NEMA L16-20R

USE OF EXTENSION CORDS



WARNING

LIVE ELECTRICAL COMPONENTS!

Failure to follow all electrical safety precautions when exposed to live electrical components could result in serious injury or death.

When it is necessary to work with live electrical components, have a qualified, licensed electrician or other individual who has been properly trained in handling live electrical components perform these tasks.

FOR OWC3612 MODEL: AN EXTENSION CORD CAN BE USED PROVIDED IT IS RATED AT LEAST 20 AMPS @ 250 VOLTS WITH GROUNDING-TYPE ATTACHMENT PLUG AND GROUNDING TYPE CONNECTOR (LOAD FITTING)

FOR OWC3632 MODEL: AN EXTENSION CORD CAN BE USED PROVIDED IT IS RATED AT LEAST 20 AMPS @ 250 VOLTS, 3- PHASE

FOR OWC3634 MODEL: AN EXTENSION CORD CAN BE USED PROVIDED IT IS RATED AT LEAST 20 AMPS @ 600 VOLTS, 3-PHASE

NOTICE

SAFETY INSTRUCTIONS

SPECIAL NOTICE — THREE PHASE OPERATION

Models OWC3632, OWC3634, OWC6032 and OWC6034

All three-phase OWC models are equipped with a three-phase monitor for added compressor protection. The phase monitor, located in the control box, has a multi-color LED that reports status. The solid state controller constantly monitors power and will display an out of phase error and sound an alarm if power is out of phase. The monitor protects the compressor from reverse operation, phase loss and low voltage situations. Further description of the three-phase monitor is located in the electrical section of this manual.

NOTICE

DO NOT OPERATE ANY THREE-PHASE UNIT WHILE BY-PASSING THE MONITOR

THIS WILL VOID THE WARRANTY

*For more details, see pg. 24

OWC INTERIOR

OWC3612/3632

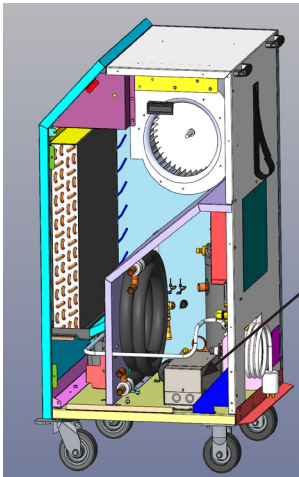
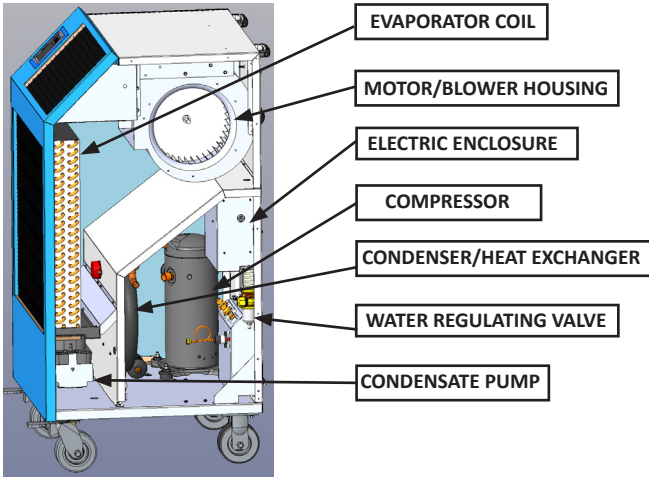

OWC3634

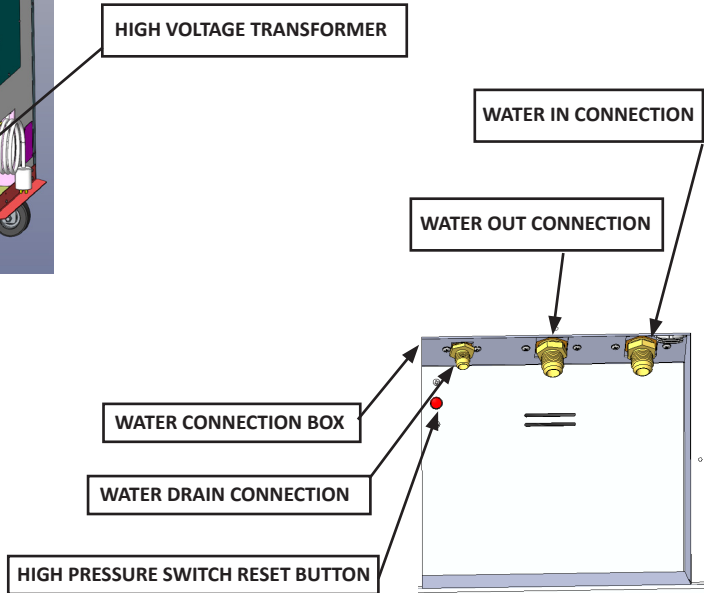

INSTALLATION INSTRUCTIONS

RECEIVING — INSPECTION

Upon receiving your unit, inspect the packaging for any damage. All units are shipped on a skid, and packaged in a double-wall carton for added protection.

BEFORE INSTALLING

Check the unit for any damage. All OceanAire products are thoroughly inspected at the factory and are carefully packaged. If any damage is evident, contact OceanAire IMMEDIATELY.

START-UP

Install the unit in accordance with all local and state building codes, and install all accessories. Allow for clearance around the unit for future maintenance and/or service. Level unit and lock casters. Connect power cord. Power up unit via controller, and check for proper operation. Refer to Controller Operation for more details.

ELECTRICAL REQUIREMENTS

Check the nameplate located on the back of the unit to confirm the proper power is available for the unit. Refer to “Specifications” section for voltage and amperage requirements. For proper NEMA receptacle, refer to “Electrical Service Plug Configuration”. When using an extension cord, use the proper gauge cord, and check cord voltage at the unit.

- TIME DELAY FUSES/CIRCUIT BREAKERS ARE RECOMMENDED

ACCESSORIES

Verify that all accessories are correct for the model, and are installed in accordance with all instructions.

WATER CONNECTION TEMPERATURE AND PRESSURE RANGE FOR UNIT OPERATION

WATER CONNECTION TEMPERATURE AND PRESSURE CHART		
	MIN	MAX
WATER TEMPERATURE	34F / 1.11C	85F / 29.4C
WATER PRESSURE	25 PSI / 172 kPa	125 PSI / 172 kPa

Use water free of foreign materials and harsh chemicals to prevent clogging or damaging the water regulator valve and heat exchanger.

When unit powered off, the water regulator valve will prevent back-flow. It is recommended to install a back-flow preventer in the line supplying the unit.

NOTICE

OPERATING THE UNIT ON IMPROPER VOLTAGE CAN DAMAGE THE UNIT AND WILL VOID THE WARRANTY

UNIT PLACEMENT FOR OPERATION

Additional clearance may be required when using accessories.

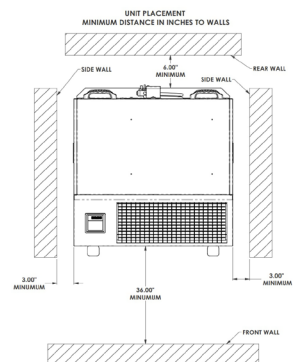

OWC Optional ACCESSORIES

NOZZLE KIT

2NK-3 (2 X 8-INCH) OWC36, 60



EVAPORATOR RETURN AIR PLENUM

DEP-16 (16-INCH ROUND) OWC36,60

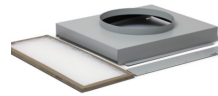

DISCHARGE DUCT ADAPTER

2DDA-16 (16-INCH ROUND) OWC36,60



HK-SERIES HOSE KIT

HK-3 10 ft Hose OWC36, 60

HK-4 25 ft Hose OWC36, 60

HK-6 40 ft Hose OWC36, 60



HK-QC SERIES HOSE KIT

HK-3QC 10 ft Hose OWC36-60QC

HK-4QC 25 ft Hose OWC36-60QC

HK-6QC 40 ft Hose OWC36-60QC



HA-QC SERIES HOSE KIT

HA-LGQC 2 ft Hose OWC36-60QC



OWC ACCESSORIES

DISCHARGE AIR NOZZLE KIT ASSEMBLY

The optional discharge nozzle kits are used to direct the conditioned air to a specific target area. By concentrating the airflow, the nozzles increase the air velocity towards production lines to cool personnel and/or equipment. In server rooms, the nozzles can be used to direct the airflow through the rack to remove the hot air from the area of the equipment.

2NK-3 for models OWC36 and OWC60

With (2) 8-inch diameter nozzles with an approximate compressed length of 20 inches. The extended length is approximately 29 inches.

The nozzle kits come pre-assembled with nozzles secured to a mounting plate, and with edge guards. By removing the OWC discharge grille, you can insert the nozzle kit into the opening without the use of tools.



CAUTION

Do not operate the OWC unit without either the discharge grille or nozzle kit installed. Failure to do will expose the unit's blower wheel, and may result in injury or component damage.



2NK-3 Nozzle Kit

OWC ACCESSORIES

EVAPORATOR RETURN AIR PLENUM

Evaporator return air plenums are available for installations where it is required to duct air to the inlet of the evaporator. The evaporator return air plenums allow the user to connect round duct (flexible or rigid) to the return air intake to reduce noise and increase the number of options for solving difficult cooling problems. The plenum attaches to the front of the unit, replacing the return air grille. Refer to the table below for configuration and application information.

DEP-16 for OWC36 and OWC60

Transitions the return opening to a 16-inch round duct.

NOTICE

When a DEP/2DEP is installed, it is recommended to set the evaporator fan speed to HIGH in manual mode, to avoid evaporator coil freeze-up.

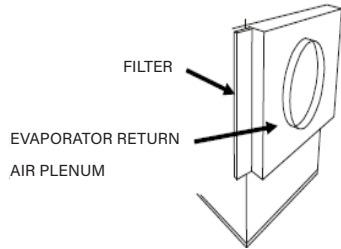
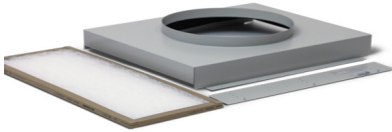

OceanAire Return Air Plenum Chart

Plenum Kit Duct/Flange	OWC18	OWC24	OWC36	OWC60	FILTERS
2DEP-12 12 inch	✓	✓			(1) 16" x 24" x 1"
DEP-16 16 inch			✓	✓	(1) 22" x 28" x 1"
Maximum Equivalent Feet	50	60	70	80	
Ext. External Static Pressure	(.25)	(.25)	(.25)	(.50)	

OWC ACCESSORIES

2DDA-Series Discharge Duct Adapter

For: ALL WATER-COOLED MODELS (OWC)

The 2DDA is a field-installed duct adapter that allows for the round duct to be connected to the supply (discharge) of the unit. The insulated adapter is designed to install onto the unit without the use of tools, and is equipped with a round, sheet metal flange for the connection of round, flexible duct. The duct adapter is designed such that it can be installed in a vertical or horizontal orientation.



The optional discharge duct adapters are available for applications where ducted evaporator discharge is required. The adapters can be easily installed on the unit without fasteners/tools, and be installed for either vertical or horizontal ducting. The standard discharge grille is removed and the adapter is attached in the grille opening.

2DDA-16 for models OWC36 and OWC60

Converts the evaporator discharge to a 16-inch diameter round duct.

When used in conjunction with the evaporator return air plenum, the unit can provide closed-loop cooling to and from a given space without the influence of any outside air.

Do not operate the OWC unit without either the discharge grille or duct adapter installed.

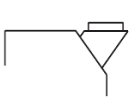

VERTICAL
DISCHARGE

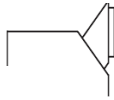

HORIZONTAL
DISCHARGE

NOTICE

When a 2DDA is installed, it is recommended to set the evaporator fan speed to **HIGH**, in manual mode, to avoid evaporator coil freeze up.

When installing the 2DDA, ensure that there is sufficient space and room for the duct to install with a minimum number of bends. Fan speeds need to be set to the highest setting possible in manual fan speed mode.

*Flexible duct can be ordered, or is field supplied.

OceanAire Duct Adapter Chart

Adapter Model	Round size	OWC18	OWC24	OWC36	OWC60
2DDA-10 10 inch	10-inch	✓	✓		
2DDA-16 16 inch	16-inch			✓	✓
Maximum Equivalent Feet		50	60	70	80
External Static Pressure		(.25)	(.25)	(.25)	(.50)

OWC ACCESSORIES

HK-Series Hose Kit

For: ALL WATER-COOLED MODELS (OWC)

All OceanAire hose kits are designed for use with OceanAire Portable Water-Cooled Air conditioners to accommodate almost any installation requirement. The hose kit allows for the unit to be connected to a water source while providing a certain level of portability and ease of installation. Hose Kits come in two sizes; 3/8-inch and 5/8 -inch, and both sizes are available in three lengths; 10-foot, 25-foot and 40-foot.

The hose kit consists of three separate hoses; WATER IN, WATER OUT and DRAIN. The WATER-IN and WATER-OUT hoses are made of reinforced PVC tubing and facilitate the water supply and water return. The DRAIN is made of gray PVC and is used for the condensate pump discharge to the drain.



HOSE KIT

NOTICE

MAXIMUM WORKING PRESSURE FOR WATER LINES: 100 PSIG

Exceeding maximum working pressure can damage hose lines, and inhibit unit operation.

FEATURE	WATER-IN HOSE WATER-OUT HOSE	CONDENSATE DRAIN HOSE
Material	PVC with Polyester Braid	Gray PVC
Wall Thickness	3/8 ID, 0.219 Wall 5/8 ID, 0.266 Wall	3/8 ID, 0.063 Wall
Nominal OD	3/8 ID, 0.594 OD 5/8 ID, 0.891 OD	3/8 ID, 0.500 Wall



SINK
ADAPTER

OceanAire Hose Kit Chart

UNIT SIDE FITTINGS

TERMINATION FITTINGS

Hose Kit Model	For Use With OWC	WATER-IN (BLACK)	WATER-OUT (RED)	DRAIN (YELLOW)	Hose Kit Length (ft)	WATER-IN	WATER-OUT	DRAIN
HK-1	18, 24	3/8 Female JIC Flare	3/8 Female JIC Flare	3/8 Female JIC Flare	10	3/4 Hose Connector*	No Fitting	No Fitting
HK-2	18, 24	3/8 Female JIC Flare	3/8 Female JIC Flare	3/8 Female JIC Flare	25	3/4 Hose Connector*	No Fitting	No Fitting
HK-5	18, 24	3/8 Female JIC Flare	3/8 Female JIC Flare	3/8 Female JIC Flare	40	3/4 Hose Connector*	No Fitting	No Fitting
HK-3	36, 60	5/8 Female JIC Flare	5/8 Female JIC Flare	3/8 Female JIC Flare	10	3/4 Hose Connector*	No Fitting	No Fitting
HK-4	36, 60	5/8 Female JIC Flare	5/8 Female JIC Flare	3/8 Female JIC Flare	25	3/4 Hose Connector*	No Fitting	No Fitting
HK-6	36, 60	5/8 Female JIC Flare	5/8 Female JIC Flare	3/8 Female JIC Flare	40	3/4 Hose Connector*	No Fitting	No Fitting

*All Hose Kits come with a 4-way Sink Adapter Fitting

Flare Connection Hose Kit

INSTALLATION INSTRUCTIONS

RECOMMENDED TIGHTENING: 1/4 TURN PAST "HAND-TIGHTENED"

Connect according to hose and unit labels:

BLACK to WATER IN

RED to WATER OUT

YELLOW to DRAIN

NOTICE

USE TWO WRENCHES WHEN CONNECTING HOSE KIT TO AVOID DAMAGING THE INTERNAL TUBING

1. Connect Hose Kit to unit, USING TWO WRENCHES. Use one wrench to secure the brass union on the unit, while using the other wrench to tighten the hose coupling unit.
2. Connect WATER IN hose to water supply using hose connection and sink adapter (if needed).
3. Install WATER OUT line in drain, allowing for free drain conditions with an air space around the tube.
4. Install DRAIN line in drain, allowing for free drain conditions.
5. Open water supply valve, and check for any water leaks in hose connections. Correct if necessary.

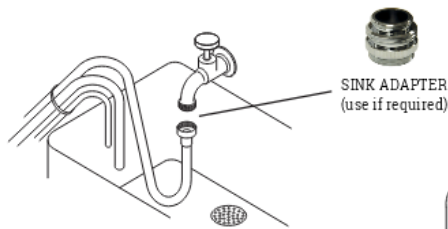
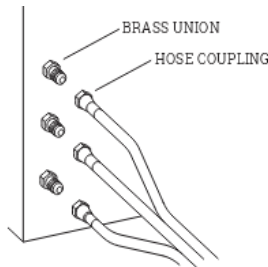
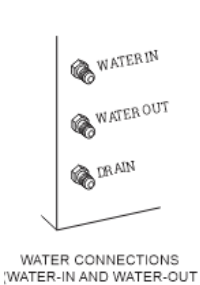

WATER CONNECTIONS
(WATER SUPPLY)
ALLOW WATER-OUT AND DRAIN LINE TO
DRAIN FREELY INTO SINK



OWC ACCESSORIES

HK-QC Series Deluxe Hose Kit

For: ALL OWC-QC MODELS

All OceanAire Quick-Connect (QC) hose kits are designed for use with OceanAire Portable Water-cooled Air conditioners equipped with Quick-Connect Fittings, to accommodate almost any installation requirement. The hose kit allows for the unit to be connected to a water source while providing a level of portability and ease of installation. The QC Hose kits come in two sizes; 3/4-inch and 5/8-inch, and both sizes are available in three lengths; 10-foot, 25-foot and 40-foot.



The hose kit consists of three separate hoses; WATER IN, WATER OUT and DRAIN. The WATER-IN (BLACK) and WATER-OUT (RED) hoses are made of reinforced PVC tubing and serve for the water supply and water return. The DRAIN (YELLOW) is made of gray PVC and is used for the condensate pump discharge to a drain.

A QC lanyard is supplied with each QC Coupling. When engaged, this device releases the internal valve of the coupling allowing for air to break the vacuum, and drain the hose.

MAXIMUM WORKING PRESSURE FOR WATER LINES: 100 PSIG

FEATURE	WATER-IN HOSE WATER-OUT HOSE	CONDENSATE HOSE (DRAIN)
Material	PVC with Polyester Braid	Gray PVC



SINK
ADAPTER

* All Hose Kits come with a 4-way Sink Adapter Fitting

HOSE KIT	MODEL NO	HOSE LENGTH	UNIT SIDE FITTINGS			HOSE COUPLER/TERMINATION		
			WATER IN	WATER OUT	DRAIN	WATER SUPPLY		DRAIN
						Female Garden Hose Connection	WATER OUT	
HK-2QC	OWC-18-24QC	25'	3/8 QC	3/8QC	1/4 QC	3/4	No Fitting	No Fitting
HK-5QC	OWC-18-24QC	40'	3/8 QC	3/8QC	1/4 QC	3/4	No Fitting	No Fitting
HK-8QC	OWC-18-24QC	75'	3/8 QC	3/8QC	1/4 QC	3/4	No Fitting	No Fitting
HK-4QC	OWC-36-60QC	25'	3/4 QC	3/4QC	3/8 QC	3/4	No Fitting	No Fitting
HK-6QC	OWC-36-60QC	40'	3/4 QC	3/4QC	3/8 QC	3/4	No Fitting	No Fitting
HK-7QC	OWC-36-60QC	75'	3/4 QC	3/4QC	3/8 QC	3/4	No Fitting	No Fitting

HA-SMQC	3/8"x3/8"x1/4" QC hose adapter
HA-LGQC	3/4"x3/4"x3/8" QC hose adapter

040-088	1/4" QC FITTING
040-035	3/8" QC FITTING
040-036	3/4" QC FITTING

HK-QC Hose Kits Installation Instructions

1. Connect Hose Kit to unit by aligning the QC Coupling with the QC Fitting on the unit. Connect the hose kit according to hose and unit labels: BLACK to WATER IN, RED to WATER OUT and YELLOW to DRAIN. HOLD the coupling behind the sleeve allowing the sleeve to move freely and PRESS firmly, until the sleeve retracts and clicks. The "click" means that the QC Coupling is engaged onto the QC Fitting.
2. Connect WATER IN hose to water supply using hose connection, and sink adapter (if needed).
3. Install WATER OUT line in drain, allowing for free drain conditions with an air space around the opening.
4. Install DRAIN line in drain, allowing for free drain conditions.
5. Open water supply valve, and check for any water leaks in hose connections.

To release the coupling, Hold the Coupling as shown below, and pull back on the sleeve. The Coupling will release and the valve inside of the coupling will seal. Once off-site, use the fitting secured to the hose kit by the lanyard to release the valve and drain the hoses.

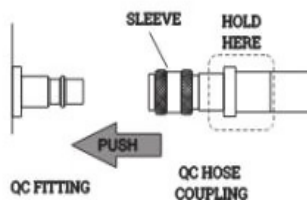
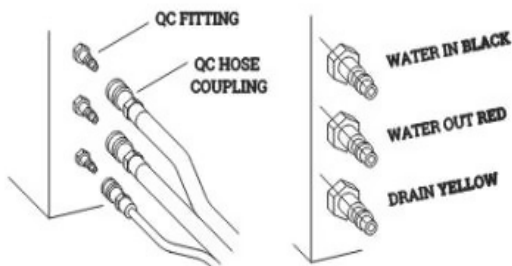

TO CONNECT
Firmly Push the Coupling onto the Fitting, until you hear a "click".

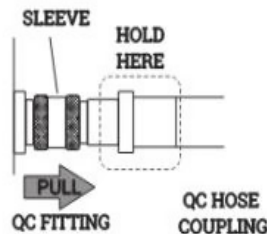

TO RELEASE
Pull the sleeve away from the fitting. It will spring back when released.

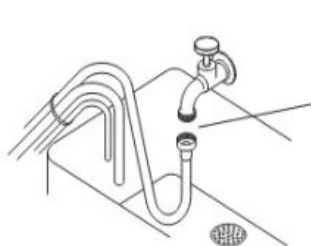

**WATER CONNECTIONS
(WATER SUPPLY)**
ALLOW WATER-OUT AND DRAIN LINE TO
DRAIN FREELY INTO SINK



**OR PLACE WATER-OUT AND DRAIN
LINES INTO DRAIN RISER**

OWC ACCESSORIES

HA-QC Series Deluxe Hose Kit

For: ALL OWC-QC MODELS



The Hose Adapter Kit allows for the installation of a OWC QC series water cooled unit where the Standard QC Hose Kit cannot accommodate the installation. The kit provides a means of connecting hoses to a QC-Model unit when the water source and drain are located in separate areas, or where longer hose runs are desired. The Hose Adapter is equipped with Quick-Connect Couplings along with the Garden Hose Connections as shown below:

FEATURE	WATER-IN HOSE WATER-OUT HOSE	CONDENSATE HOSE
Material	PVC with Polyester Braid	Gray PVC

HOSE KIT PART NO.	For Use With	WATER IN	WATER OUT	DRAIN	LENGTH	WATER SUPPLY	WATER OUT	DRAIN
HA-LGQC	OWC36QC OWC60QC	3/4 QC Coupling	3/4 QC Coupling	3/8 QC Coupling	2 ft.	3/4 Female Garden Hose	3/4 Male Garden Hose	3/8 Hose Barb

DELUXE ELECTRONIC CONTROLLER

The OWC controller is equipped with many features for a more precise level of cooling and dehumidification operation. With the addition of a remote sensor, the controller can sense temperatures in another space or in ductwork. Sensing temperature overrides the temperature sensing bulb located behind the evaporator grille.



OceanAire DELUXE ELECTRONIC CONTROLLER

When the unit is plugged in the Green Plug icon will illuminate indicating the unit is receiving power. Press the Power Button The controller will display your unit Type, Refrigerant and Model. Example: "H2O" for water cooled, "454" for 454b refrigerant, then "3612" for Model number. When powered on the controller will automatically check for correct power phase if 3-phase unit and correct line voltage on non-3-phase units. If power is out of phase the controller will display "ERR" + "PWR". If line voltage is out of operational range the controller will display "ERR" + "PWR". If a 3-phase or line voltage error occurs have a certified electrician check the building's power receptacles. If 3-phase power is OK and line voltage is in range no error will be displayed and you are OK to operate your unit.

The system controls temperature within +/-2 degrees F

Controller Button and Icon Table

POWER – Turns the unit on/off when power is supplied

MODE – Toggles the mode of operation between Cooling and Moisture Control

MODE SELECT – Press the **MODE** Button to toggle between “COOL” and “DHUM”. Controller display will show “COOL” then “DHUM”. When desired mode is shown Press the **GEAR** Button to accept

FAHRENHEIT / CELSIUS – Controller can display temperature in Fahrenheit or Celsius.

FAHRENHEIT / CELSIUS SELECT – Press the **THERMOMETER** Button and **MODE** Button simultaneously to toggle between “F” and “C”. Controller display will illuminate “F” or “C”. When desired Temperature mode is illuminated, press the **GEAR** Button to accept

SETPOINT TEMPERATURE – In Cooling mode your OWC unit can be set to operate between 60F(16C) and 85F (29C)

SETPOINT TEMPERATURE ADJUST – Press the **UP-ARROW** Button to increase the setpoint temperature in 1-degree increments. Press the **DOWN-ARROW** Button to decrease the setpoint temperature in 1-degree increments. Controller display will show setpoint temperature change with each button press, when desired setpoint is shown no further button press required controller will automatically accept the new setpoint temperature

FAN SPEED – You can set your OWC to operate in **AUTO** fan speed mode or **MANUAL** fan speed mode. Manual fan speed mode has six fan speed selections







FAN SPEED MODE SELECT – Press the **FAN** Button to toggle between **AUTO** fan speed and **Manual** fan speed levels. For **AUTO**, press the **FAN** Button until “**AUTO**” illuminates next to the fan speed indicator bar. Press the **GEAR** Button to accept. For **MANUAL** fan speed, press the **FAN** Button until “**MANUAL**” illuminates next to the fan speed indicator bar. The first bar on the speed indicator will illuminate. This is fan speed 1. Fan speed will advance through all 6 speeds with each **FAN** Button press. When desired fan speed is reached, press the **GEAR** Button to accept. With the unit plugged in and powered off you can set the evaporator fan to continuous run or auto cycle run. To accept the desired running mode, press and hold the fan icon button, display **CON**, press up arrow to advance to **CYL**, and press gear icon.















ALARM / ERROR – In the event of a system **ALARM** or **ERROR**, the controller will display an **ERROR** message and the **ALARM** beeper will sound. To silence the alarm, press the **ALARM** Button. See **ERROR CODE TABLE** for list of error codes, system responses and required action.

TEMPERATURE DISPLAY PROBE SELECT— Press the **Thermometer** Button to cycle through the four temperature display modes. The controller will cycle through the four options and the icon at the top of the controller will illuminate . “**INSIDE**” will display Ambient temperature, “**DISCHARGE**” will display discharge air temperature, “**SETPOINT**” will display unit setpoint temperature and “**EXTERNAL**” will display remote ambient temperature if probe is installed. When the desired mode of temperature display is illuminated, press the **GEAR** Button to accept.

Note: Moisture control mode operation – The unit operates the cooling system to reduce humidity within the conditioned space. The controller constantly checks ambient room temperature if temperature drops 2 degrees below setpoint the compressor will turn off and the fan will remain on circulating air. Your OWC unit will continue to monitor ambient temperature and cycle Moisture Control as needed.

Note: When in **MANUAL** fan speed mode your OWC may change fan speed to protect the unit’s compressor.

CONTROLLER BUTTONS	
	POWER BUTTON
	MODE BUTTON
	THERMOMETER BUTTON
	ALARM/BEEPER BUTTON
	UP / DOWN ARROW BUTTON
	FAN SPEED BUTTON
	GEAR BUTTON

CONTROLLER ICONS	
	POWER = Indicates unit is plugged in
	HEAT MODE = Indicates unit is in heat mode
	AUTO MODE = Indicates unit is in AUTO cool/heat mode
	COOL MODE = Indicates unit is in cooling mode
	DEHUMIDIFY MODE = Indicates unit is in dehumidification mode
	WARNING = Indicates unit is in alarm or error mode
	FAN SPEED = Indicates level of fan speed in manual mode
	AUTO FAN MODE = Indicates unit is in auto adjust fan speed
	MANUAL FAN MODE = Indicates unit is in manual select fan speed
	FAHRENHEIT MODE = Indicates unit temperature is set to F
	CELSIUS MODE = Indicates unit temperature is set to C
	TEMPERATURE DISPLAY = Controller will display Ambient temperature
	TEMPERATURE DISPLAY = Controller will display Evaporator discharge air temperature
	TEMPERATURE DISPLAY = Controller will display user setpoint temperature
	TEMPERATURE DISPLAY = Controller will display Ambient temperature at remote probe if installed

ALARM/ERROR CODES

ERROR CODE	ERROR TITLE	ERROR CONDITION	SYSTEM RESPONSE	CORRECTIVE ACTION
ERR + MC	Machine Control Circuit	MC detects an internal circuit failure that prevents it from operating properly	Display ERR + MC, Sound Alarm, unit will not operate	Contact OceanAire Tech Support
ERR + UI	User Interface Circuit	UI detects an internal circuit failure that prevents it from operating properly	Display ERR + UI, Sound Alarm, unit will not operate	Contact OceanAire Tech Support
ERR + COMM	UI/MC communications error	UI is unsuccessful at communicating with the MC	Display ERR + COMM, Sound Alarm, unit will not operate	Contact OceanAire Tech Support
ERR + USB	Universal Serial Bus	USB download unsuccessful	Display ERR + USB	Contact OceanAire Tech Support
ERR + LPWR	Line Voltage Out of Range	non-3-Phase power voltage at end user receptacle is out of range	Display ERR + LPWR, Sound Alarm, unit will not operate	Contact OceanAire Tech Support. Have certified Electrician check building power / receptacle(s)
ERR + PHAS	Power Connection out of Phase	3-Phase power at end user receptacle is out of Phase	Display ERR + PHAS, Sound Alarm, unit will no operate	Contact OceanAire Tech Support. Have certified Electrician check building power / receptacle(s)
ERR + TP-1	Temperature Sensor #1	Controller is not receiving sensor signal	Display ERR + TP-1, Sound Alarm, unit will continue to operate	Contact OceanAire Tech Support, Replace TP-1
ERR + TP-2	Temperature Sensor #2	Controller is not receiving sensor signal	Display ERR + TP-2, Sound Alarm, unit will continue to operate	Contact OceanAire Tech Support, Replace TP-2
ERR + TP-3	Temperature Sensor #3	Controller is not receiving sensor signal	Display ERR + TP-3, Sound Alarm, unit will continue to operate	Contact OceanAire Tech Support, Replace TP-3
ERR + TP-4	Temperature Sensor #4	Controller is not receiving sensor signal	Display ERR + TP-4, Sound Alarm, unit will continue to operate	Contact OceanAire Tech Support, Replace TP-4
ERR + TP-5	Temperature Sensor #5	Controller is not receiving sensor signal	Display ERR + TP-5, Sound Alarm, unit will continue to operate	Contact OceanAire Tech Support, Replace TP-5
ERR + HP-1	High Pressure Switch	High Pressure Switch reads pressure that exceeds the maximum allowed	Display ERR + HP-1, Sound Alarm, unit will not run until pressure is in operating range	Manually Reset High Pressure Switch. Contact OceanAire Tech Support if ERROR persists
ERR + LP-1	Low Pressure Switch	Low Pressure Switch reads pressure below minimum allowed	Display ERR + LP-1, Sound Alarm, unit will not run until pressure is in operating range	Contact OceanAire Tech Support
ERR + LDET	Refrigerant Leak Detected	Leak in Refrigeration System	Display ERR + LDET, Sound Alarm, Refrigeration System Shut Down, All unit fans turn on	Contact OceanAire Tech Support
FULL - TANK	Consate Tank	Condensate is full	Display FULL + TANK, Sound Alarm, unit will continue to operate	Power off unit and un-plug, Remove condensate tank and empty, replace empty tank, plug in unit and power on

NOTICE

DO NOT REMOVE ANY UNIT PANELS OR ATTEMPT ANY SELF REPAIR. CONTACT OCEANAIRE TECH SUPPORT.

**ALL REPAIRS SHOULD BE MADE BY A CERTIFIED/
LICENSED ELECTRICIAN/HVAC SERVICE TECH**

WATER VALVE

Each OceanAire WATER-COOLED unit is equipped with an automatic water regulating valve to control the condenser water flow rate. The water valve will open when the unit is in cooling mode and adjust the gallon per minute flow rate based on the entering water temperature (EWT).

The water valve operates independently from the water system, and regulates flow based on the system's refrigerant head pressure.

Under certain conditions, entering water temperatures can cause the valve to rapidly open and close, causing a "harmonic" pitch in the water supply line. In these cases, it is recommended that the water valve be adjusted. Consult OceanAire TECH support for adjustment procedure.

Regarding a field replacement water valve, the best practice is to close the valve, turn the range adjustment screw in clockwise half-turns to slowly open it, and dial in the unit's exiting water temperature between 100-105°F.



WARNING

IT IS RECOMMENDED THAT ALL OCEANAIRE UNITS BE SERVICED OR ADJUSTED BY LICENSED TECHNICIAN TO AVOID INJURY, DISCONNECT UNIT PRIOR TO SERVICING

CONTACT

techsupport@oceanaire-inc.com

(847) 583-0311

WATER VALVE ADJUSTMENT

Each OCEANAIRE WATER-COOLED unit is equipped with an automatic water regulating valve to control the condenser water flow rate. The water valve will open when the unit is in the cooling mode and adjust the water flow rate based on the entering water temperature (EWT) and heat load.

The water valve operates independently from the water system, and regulates flow based on the system's refrigerant head pressure.

Under certain conditions, entering water temperatures can cause the valve to rapidly open and close, causing a "harmonic" pitch in the water supply line.

In these cases, it is recommended that the water valve be adjusted.

1. Disconnect unit power.
2. Remove unit side panel (depending on model) to locate the water valve.
3. At the top of the valve, there is a square shaped adjustment screw. Using a standard service wrench or flat blade screwdriver, adjust the valve using quarter turns, allowing the unit to operate approximately 5 minutes after each new setting.
 - CLOCKWISE (CW) lowers the valve's set point to open.
 - COUNTER-CLOCKWISE (CCW), closes the valve, which raises HIGH side pressure, and raises the valve's set point to open.
4. Re-install side panel when finished.

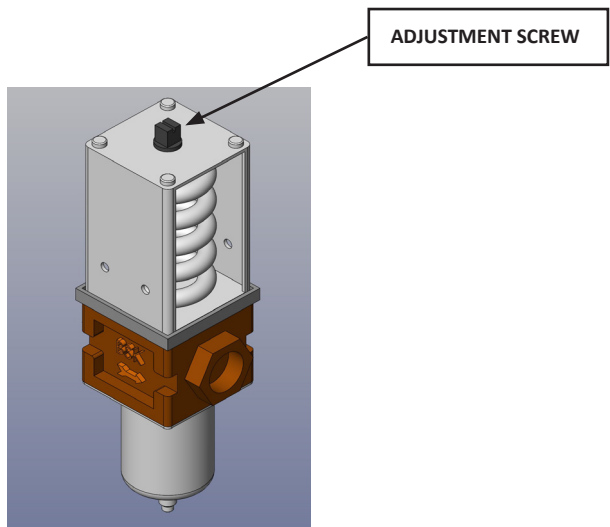

PREVENTIVE MAINTENANCE

NOTICE

It is recommended to follow the instructions specified below to extend the lifespan of the unit, and avoid damage to its components.

OFF SEASON STORAGE—WINTERIZATION

Before placing the unit into storage for the off-season, it is recommended to thoroughly clean the unit, and remove all water in the CONDENSER COIL, WATER LINES, DRAIN PAN and CONDENSATE PUMP to avoid damage to the unit from freezing water or contamination.

DRAINING THE CONDENSER COIL AND INTERIOR LINES

To drain the condenser coil, detach the WATER IN and WATER OUT lines. Using a Shop-Vac or similar device, vacuum the WATER OUT line and start the unit. The water valve will open, allowing you to vacuum out the condenser coil. Eventually, the High Pressure Cut-Out will shut down the compressor. Wait 15 minutes, depress the HIGH PRESSURE RESET and repeat the process until ALL of the water is out of the system. When completed, depress the HIGH PRESSURE RESET one final time to make sure system is reset.

DRAINING THE HOSE KIT

To drain the hose kit, disconnect all hoses, and allow them to gravity drain.

EVACUATING THE CONDENSATE PUMP

Using a Shop-Vac or similar device, vacuum all water out of the condensate pump reservoir. Condensate pumps come standard with all OWC models. When servicing the pump, follow these steps:

- 1) Make certain the unit is disconnected from the power source before attempting to service or remove any component.
- 2) Be sure the floats move freely. Clean as necessary.
- 3) Remove the pump assembly and check for obstructions. Clean as necessary.
- 4) Clean the reservoir with warm water and mild soap when mineral deposits are visible.
- 5) Check the inlet outlet piping. Clean as necessary. Be sure there are no kinks in the lines that would inhibit flow.

CLEANING THE UNIT

Wipe down the outside surface of the unit using a damp lint-free cloth and let dry completely. Wash and vacuum the evaporator coil taking care not to bend or damage the coil fins, let dry completely.

BLOWER / FAN MOTOR

The evaporator motor on all units have permanently lubricated bearings. No oiling necessary.

FILTER

A clogged filter will cause the unit to operate at greatly reduced efficiencies. We recommend that the filter be inspected on a regular basis (every six weeks or less) depending on the environment. The evaporator filter is located behind the return air grille and can be easily removed and cleaned. The filter must be washed periodically as needed by placing it in a dishwasher or soaking in a solution of warm water and detergent for 10 minutes. Then rinsing clean with hot water and shaking excess moisture from filter.

GENERAL

OceanAire products are NOT approved for outdoor use. Therefore, off-season storage should be indoor and protected from weather conditions. When necessary maintenance steps outlines above are followed, the air conditioner will provide long and reliable service. The refrigeration and electrical circuits of the system should only be serviced by a fully qualified service technician.

THREE PHASE MONITOR (ON 3-PH UNITS ONLY)



WARNING

LIVE ELECTRICAL COMPONENTS!

Failure to follow all electrical safety precautions when exposed to live electrical components could result in death or serious injury. When it is necessary to work with live electrical components, have a qualified licensed electrician or other individual who has been properly trained in handling live electrical components perform these tasks.

OceanAire Three-Phase units are equipped with phase monitors for compressor motor protection. The Three-Phase Monitor safeguards the compressor against phase reversal, phase imbalance and/or phase loss. The monitor is installed in the control box and is equipped with LED's for diagnosis of electrical conditions. The OWC Three-Phase unit(s) monitor is also equipped with phase detection.

When power is connected and unit is turned on, the OWC controller will check phase before sending power to any component. If power is out of phase the display will show "ERR" + "PHAS" and sound an alarm. If the Phase alarm has sounded, remove the control box access cover to observe the LED's on the Phase Monitor.

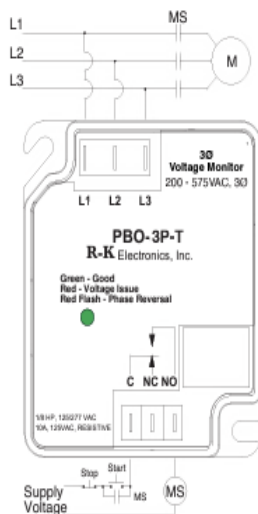

Three Phase Monitor — PBO-3P-T-LED's

The PBO-3P-T monitors 5 three phase voltages with the tolerances pre-programmed into the PBO. Each time the PBO is powered up, the processor evaluates the line voltage and compares it to the pre-programmed line voltages and tolerances. If the line voltage matches one of the programmed voltages and is within the tolerances, the out-put relay will be energized and the LED will be GREEN. The PBO will indicate what voltage it is set for by flashing the LED GREEN in a sequence corresponding to the selected voltage. If a voltage fault is detected, the LED will be RED and if the Phases are reversed, the LED will FLASH RED.

3Ø VOLTAGES

208VAC, 3Ø 1 GREEN FLASH
230VAC, 3Ø 2 GREEN FLASHES
380VAC, 3Ø 3 GREEN FLASHES
460VAC, 3Ø 4 GREEN FLASHES
575VAC, 3Ø 5 GREEN FLASHES

LED's

GOOD — CONTINUOUS GREEN
FAULT ROTATION — FLASHING RED
FAULT VOLTAGE — SOLID RED

PIPING SCHEMATIC

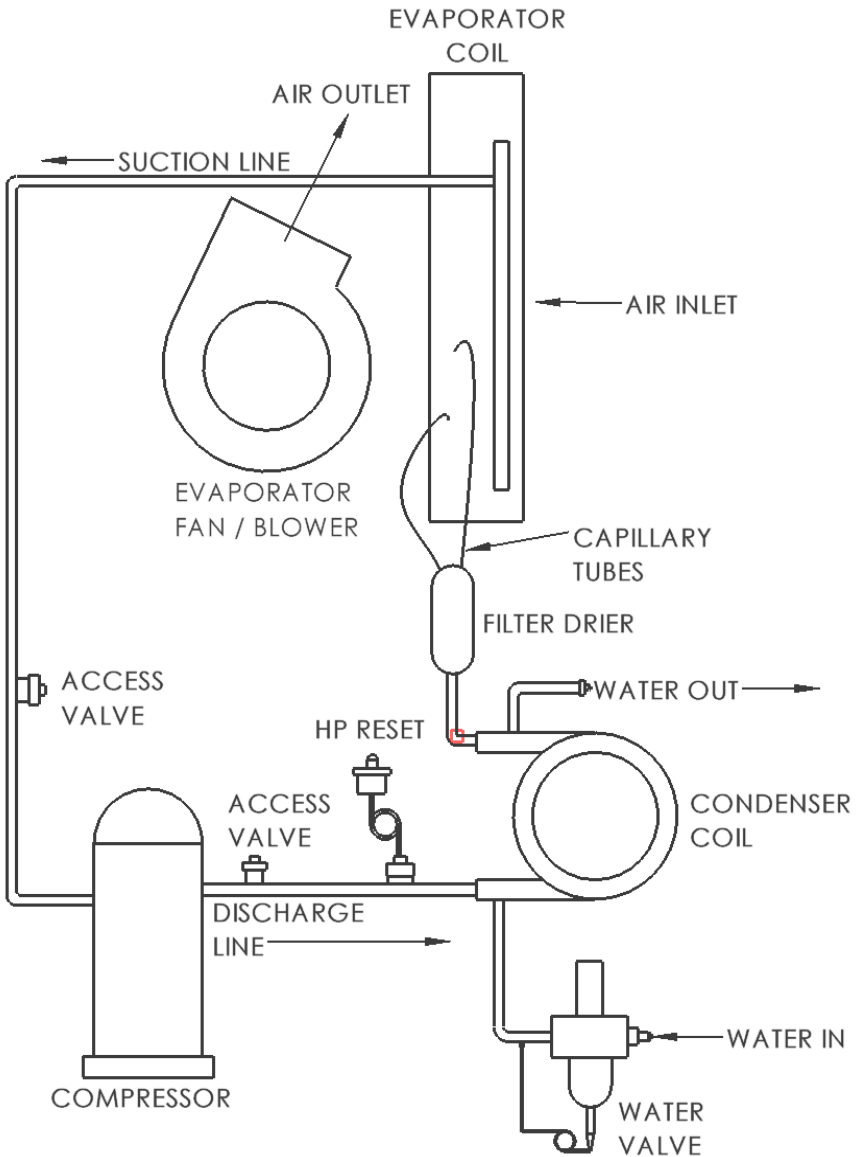

PIPING SCHEMATIC
Water-Cooled Spot Cooler

WIRING DIAGRAM FOR OWC3612

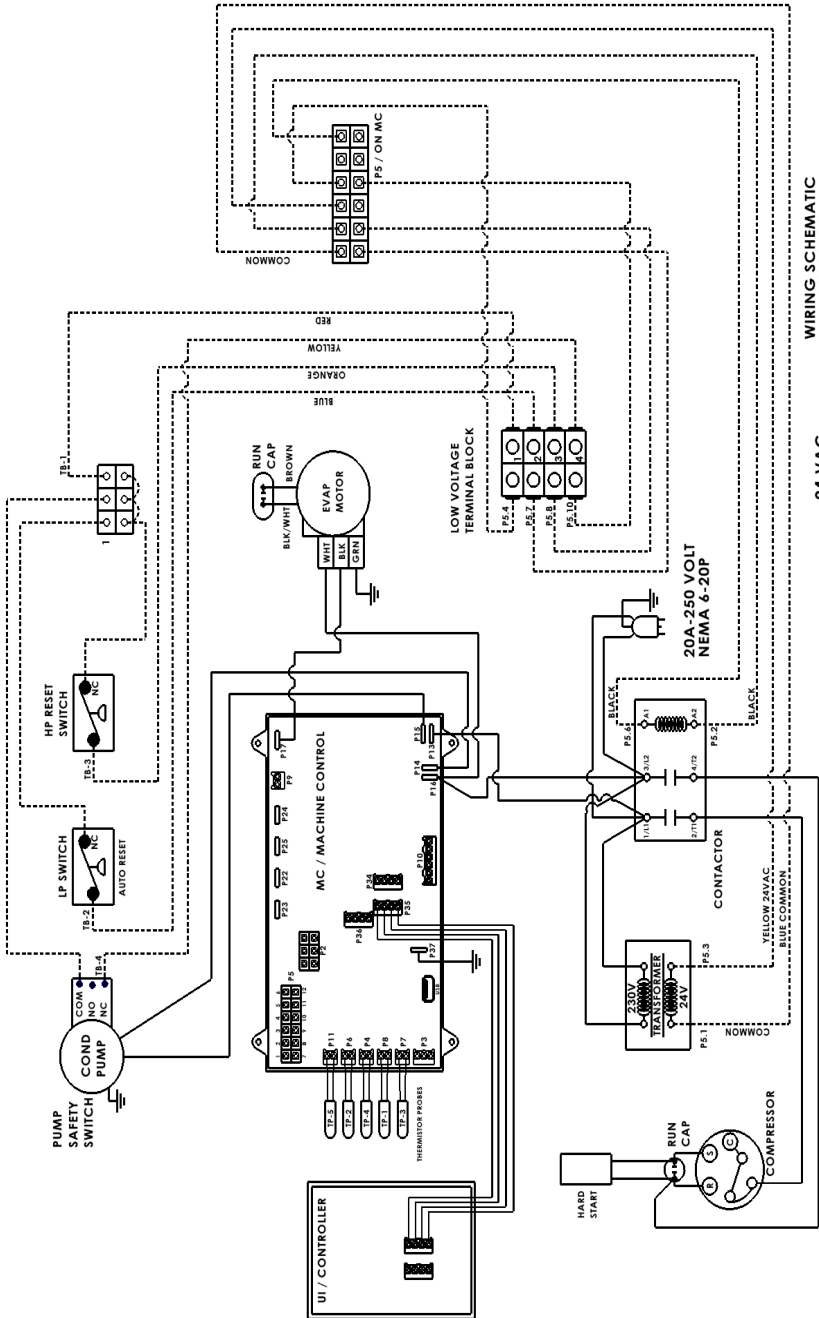

----- 24 VAC
 _____ LINE VOLTAGE 208-230V / SINGLE PHASE
 WIRING SCHEMATIC
 OWC3612

WIRING DIAGRAM FOR OWC3632

WIRING SCHEMATIC FOR OWC3632 WATER-COOLED SPOT COOLER MODEL OWC3632 208-230 VOLT / THREE PHASE

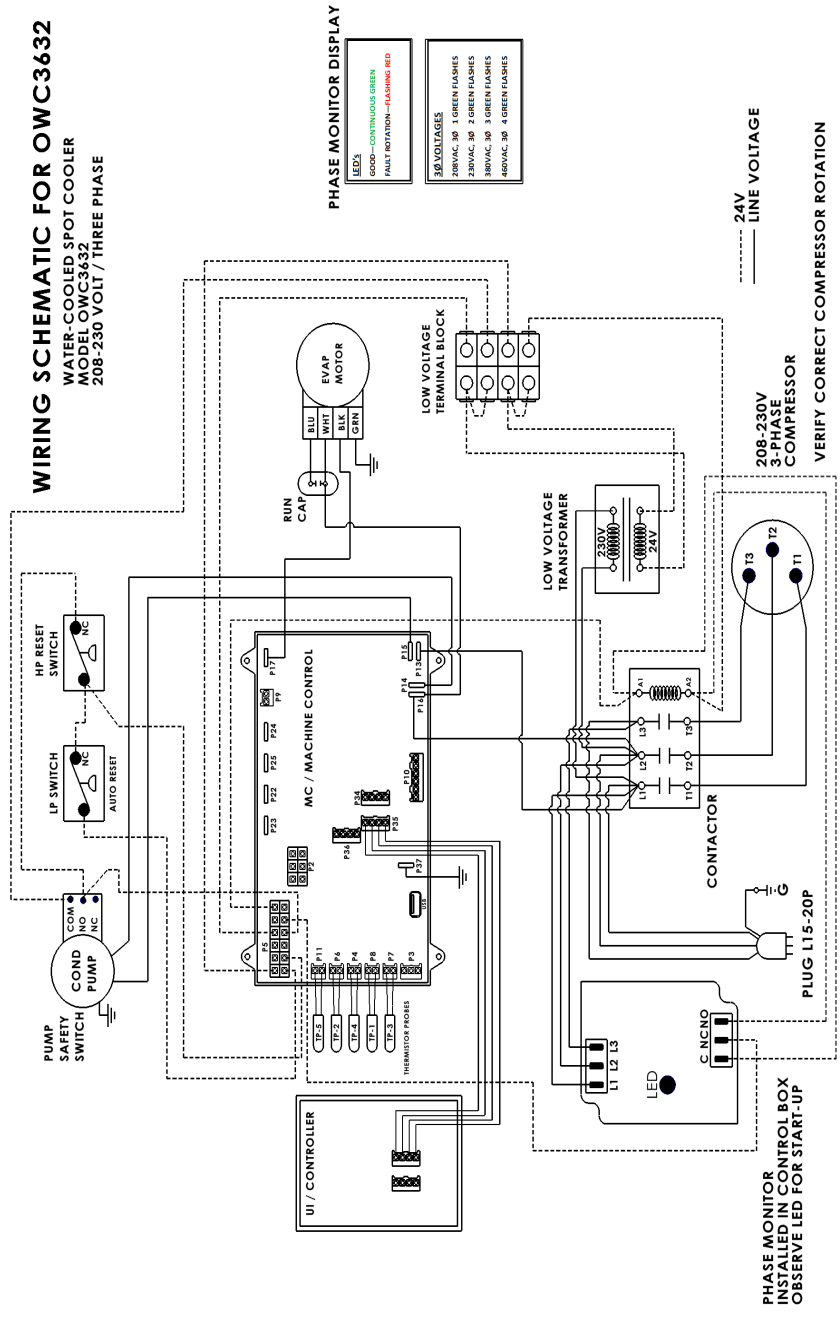

PHASE MONITOR DISPLAY

LED	GOOD—CONTINUOUS GREEN
	FAULT ROTATION—FLASHING RED

3Ø VOLTAGES	208VAC, 3Ø 1 GREEN FLASHES
	230VAC, 3Ø 2 GREEN FLASHES
	380VAC, 3Ø 3 GREEN FLASHES
	400VAC, 3Ø 4 GREEN FLASHES

----- 24V
 _____ LINE VOLTAGE

208-230V
 3-PHASE
 COMPRESSOR
 VERIFY CORRECT COMPRESSOR ROTATION

PHASE MONITOR
 INSTALLED IN CONTROL BOX
 OBSERVE LED FOR START-UP

WIRING DIAGRAM FOR OWC3634

**WIRING SCHEMATIC FOR
OWC3634 / OWC6034
WATER-COOLED SPOT COOLER
MODEL OWC3634 / OWC6034
460 VOLT / THREE PHASE**

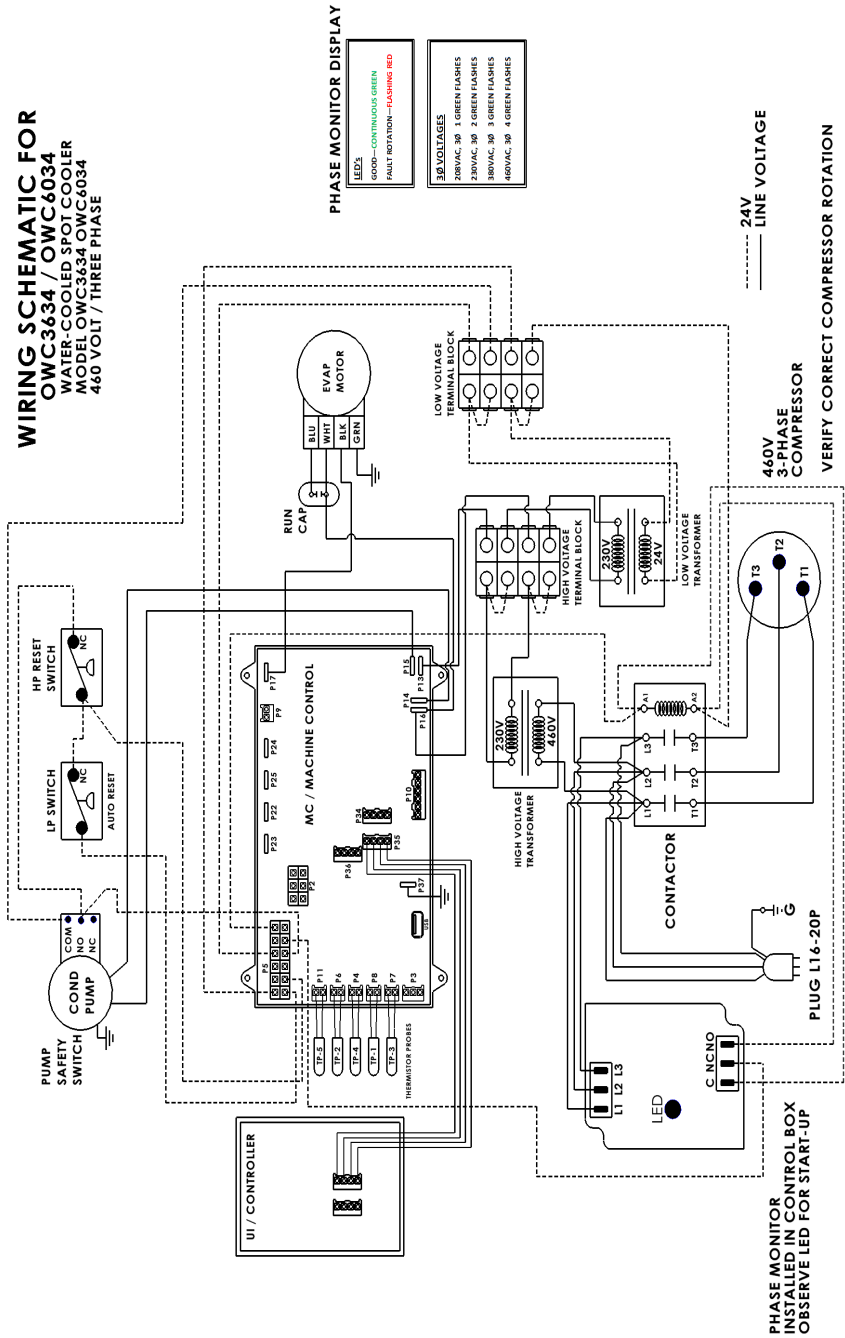

LIMITED WARRANTY

The Manufacture (OceanAire, Inc.) warrants to the original owner that the Product will be free from defects in material or workmanship for a period not to exceed one (1) year from date of installation. If upon examination by the Manufacturer, the Product is shown to have a defect in material or workmanship during the warranty period, the Manufacturer will repair or replace, at its option, that part of the Product which is shown to be defective.

The Manufacturer further warrants that the product's compressor-motor will be free from defects in materials and workmanship for five (5) years from date of installation.

If upon examination by the Manufacturer the Product is shown to have a defect in materials or workmanship during the warranty period, the Manufacturer will repair or replace, at its option, that Part of the Product which is shown to be defective.

Compressor warranty shall be pro-rated for years 2—5 at the sole discretion of OceanAire. Electrical parts such as relays, overloads, capacitors, etc., and the sealed refrigeration system (condenser and evaporator) are included in the one (1) year limited warranty, but not with the five (5) year limited warranty of the compressor.

This limited warranty does not apply to:

- A) Product that has been subjected to misuse or neglect, has been accidentally or intentionally damaged, has not been installed, maintained or operated in accordance with the furnished written instructions, or has been altered or modified in any way.
- B) Product that has been subjected to any abnormal power conditions such as loss of power, power surges, voltage irregularities such as brown-outs or phase loss on three-phase equipment.
- C) Any expenses, including labor or material, incurred during removal or reinstallation of the Product.
- D) Any workmanship of the installer of the Product.

This limited warranty is conditional upon:

- A) Return to the Manufacturer, of the part of the Product thought to be defective. Goods can only be returned with prior written approval from the Manufacturer. All returns must be freight prepaid.
- B) Determination, in the reasonable opinion of the Manufacturer, that there exists a defect in material or workmanship.

Repair or replacement of any part under this Limited Warranty shall not extend the duration of the warranty with respect to such repaired or replaced part beyond the stated warranty period.

THIS LIMITED WARRANTY IS IN LIEU OF ALL OTHER WARRANTIES, EITHER EXPRESSED OR IMPLIED, AND ALL SUCH OTHER WARRANTIES, INCLUDING WITHOUT LIMITATION IMPLIED WARRANTIES OF MERCHANTABILITY OR FITNESS FOR A PARTICULAR PURPOSE, ARE HEREBY DISCLAIMED AND EXCLUDED FROM THIS LIMITED WARRANTY. IN NO EVENT SHALL THE MANUFACTURER BE LIABLE IN ANY MANNER WHATSOEVER, OR FOR ANY AMOUNTS IN EXCESS OF THE SELLING PRICE OF THE PRODUCT OR ANY PARTS THEREOF FOUND TO BE DEFECTIVE. THIS LIMITED WARRANTY GIVES THE ORIGINAL OWNER OF THE PRODUCT SPECIFIC LEGAL RIGHTS. YOU MAY ALSO HAVE OTHER RIGHTS WHICH MAY VARY BY EACH JURISDICTION.

⚠️ WARNING

Failure to adhere to described instructions may result in serious injury or death.

NOTICE

Failure to adhere to instructions below may result in immediate or premature component failure.

ADDITIONAL SAFETY WARNINGS AND NOTICES

Do not use means to accelerate the defrosting process or to clean, other than those recommended by the manufacturer.

The appliance shall be stored in a room without continuously operating ignition sources (for example: open flames, an operating gas appliance or an operating electric heater).

Do not pierce or burn.

Be aware that refrigerants may not contain an order.

Keep any required ventilation openings clear of obstruction.

Servicing shall be preformed only as recommended by the manufacturer.

Ducts connected to an appliance shall not contain a POTENTIAL IGNITION SOURCE.

For appliances using A2L REFRIGERANTS connected via an air duct system to one or more rooms, the supply and return air shall be directly ducted to the space. Open areas such as false ceilings shall not be used as a return air duct.

The appliance is not to be used by persons (including children) with reduced physical, sensory or mental capabilities, or lack of experience and knowledge, unless they have been given supervised not to play with the appliance.

For unit operation, minimum permissible distance to adjacent structures, See figure on page 10 of this manual. Additional clearance may be required when using duct adapter kits.

It is not recommended to use the unit at elevations above 7,000 feet.

⚠️ WARNING

Failure to adhere to described instructions may result in serious injury or death.

NOTICE

Failure to adhere to instructions below may result in immediate or premature component failure.

INFORMATION ON SERVICING

CHECKS TO THE AREA: Prior to beginning work on systems containing FLAMMABLE REFRIGERANTS, safety checks are necessary to ensure that the risk of ignition is minimized.

WORK PROCEDURE: Work shall be undertaken under a controlled procedure so as to minimize the risk of a flammable gas or vapor being present while the work is being performed.

GENERAL WORK AREA: All maintenance staff and others working in the local area shall be instructed on the nature of the work being carried out. Work in confined spaces shall be avoided.

CHECKING FOR PRESENCE OF REFRIGERANT: The area shall be checked with an appropriate refrigerant detector prior to, and during work, to ensure the technician is aware of potentially toxic or flammable atmospheres. Ensure that the leak detection equipment being used is suitable for use with all applicable refrigerants, i.e. non-sparking, adequately sealed or intrinsically safe.

PRESENCE OF A FIRE EXTINGUISHER: If any hot work is to be conducted on the refrigerating equipment or any associated parts, appropriate fire extinguishing equipment shall be available at hand. Have a dry powder or CO2 fire extinguisher adjacent to the charging area.

NO IGNITION SOURCES: No person carrying out work in relation to a REFRIGERATING SYSTEM which involves exposing any pipe work shall use any sources of ignition in such a manner that it may lead to the risk of a fire or explosion. All possible ignition sources, including cigarette smoking, should be kept sufficiently far away from the site of installation, repairing, removing and disposal, during which refrigerant can possibly be released to the surrounding space. Prior to work taking place, the area around the equipment is to be surveyed to make sure that there are no flammable hazards or ignition risks. A "NO SMOKING" sign shall be displayed.

VENTILATED AREA: Ensure that the area is in the open or that it is adequately ventilated before breaking into the system or con-ducting any hot work. A degree of ventilation shall continue during the period that the work is carried out. The ventilation should safely disperse any released refrigerant and preferably expel it externally into the atmosphere.

CHECKS TO THE REFRIGERATING EQUIPMENT: Where electrical components are being changed, they shall be fit for the purpose and to the correct specification. At all times the manufacturer's maintenance and service guidelines shall be followed. If in doubt, consult the manufacturer's technical department for assistance. The following checks shall be applied to installations using

FLAMMABLE REFRIGERANTS:



**R-454B
A2L**

- The actual REFRIGERANT CHARGE is in accordance with the room size within which the refrigerant containing parts are installed
- The ventilation machinery and outlets are operating adequately and are not obstructed
- If an indirect refrigerating circuit is being used, the secondary circuit shall be checked for the presence of refrigerant
- Marking to the equipment continues to be visible and legible. Markings and signs that are illegible shall be corrected

Refrigerating pipe or components are to be installed in a position where they are unlikely to be exposed to any substance which may corrode refrigerant containing components, unless the components are constructed of materials which are inherently resistant to being corroded or are suitably protected against being so corroded.

CHECKS TO ELECTRICAL DEVICES: Repair and maintenance to electrical components shall include initial safety checks and component inspection procedures. If a fault exists that could compromise safety, then no electrical supply shall be connected to the circuit until it is satisfactorily dealt with. If the fault cannot be corrected immediately but it is necessary to continue operation, an adequate temporary solution shall be used. This shall be reported to the owner of the equipment so all parties advised.

WARNING

Failure to adhere to described instructions may result in serious injury or death.

NOTICE

Failure to adhere to instructions below may result in immediate or premature component failure.

INFORMATION ON SERVICING (CONTINUED)

Checks to Electrical devices (cont)

Initial safety checks shall include:

- The capacitors are discharged: this shall be done in a safe manner to avoid possibility of sparking
- That no live electrical components and wiring are exposed while charging, recovering or purging the system
- That there is continuity of earth bonding

REPAIRS TO SEALED COMPONENTS: During repairs to sealed components, all electrical supplies shall be disconnected from the equipment being worked upon prior to any removal of sealed covers, etc. if it is absolutely necessary to have an electrical supply to equipment during servicing, then a permanently operating form of leak detection shall be located at the most critical point of a potentially hazardous situation. Particular attention shall be paid to the following to ensure that by working on electrical components, the casing is not altered in such a way that the level of protection is affected. This shall include damage to cables, excessive number of connections, terminals not made to the original specification, damage to seals, incorrect fitting of glands, etc. ensure that seals or sealing materials have not degraded to the point that they no longer serve the purpose of preventing the ingress of flammable atmospheres. Replacement parts shall be in accordance with the manufacturer's specifications. Sealed electrical components shall be replaced.

REPAIR TO INTRINSICALLY SAFE COMPONENTS: Do not apply any permanent inductive or capacitance loads to the circuit without ensuring that this will not exceed the permissible voltage and current permitted for the equipment in use.

Intrinsically safe components are the only types that can be worked on while live in the presence of a flammable atmosphere. The test apparatus shall be at the correct rating. Replace components only with parts specified by the manufacturer. Other parts may result in the ignition of refrigerant in the atmosphere from a leak.

CABLING: Check that the cabling will not be subject to wear, corrosion, excessive pressure, vibration, sharp edges or any other adverse environmental effects. The check shall also take into account the effects of aging or continual vibration from sources such as compressors or fans.

DETECTION OF FLAMMABLE REFRIGERANTS: Under no circumstances shall potential sources of ignition be used in the searching for or detection of refrigerant leaks. A halide torch or any other detector using a naked flame shall not be used.

The following leak detection methods are deemed acceptable for all refrigerant systems. Electronic leak detectors may be used to detect refrigerant leaks but, in the case of FLAMMABLE REFRIGERANTS, the sensitivity may not be adequate, or may need re-calibration. Detection equipment shall be calibrated in a refrigerant-free area. Ensure that the detector is not a potential source of ignition and is suitable for the refrigerant used. Leak detection equipment shall be set at a percentage of the LFL of the refrigerant and shall be calibrated to the refrigerant employed, and the appropriate percentage of gas (25% maximum) is confirmed. Leak detection fluids are also suitable for use with most refrigerants but the use of detergents containing chlorine shall be avoided as the chlorine may react with the refrigerant and corrode the copper pipe-work. If a leak is suspected, all naked flames shall be re-moved/extinguished. If a leakage of refrigerant is found which requires brazing, all of the refrigerant shall be recovered from the system, or isolated by means of shut off valves in a part of the system remote from the leak.

REMOVAL AND EVACUATION: When breaking into the refrigerant circuit to make repairs—for any other purpose—conventional procedures shall be used. However, for FLAMMABLE REFRIGERANTS it is important that the best practice is followed since flammability is a consideration. The following procedure shall be adhered to: Remove refrigerant; Purge the circuit with inert gas (optional for A2L); Evacuate (optional for A2L); Continuously flush or purge with inert gas when using flame to open circuit and open the circuit

⚠ WARNING

Failure to adhere to described instructions may result in serious injury or death.

NOTICE

Failure to adhere to instructions below may result in immediate or premature component failure.

INFORMATION ON SERVICING (CONTINUED)

The refrigerant charge shall be recovered into the correct recovery cylinders if venting is not allowed by local and national codes. For appliances containing flammable refrigerants, the system shall be purged with oxygen-free nitrogen to render the appliance safe for flammable refrigerants. This process might need to be repeated several times. Compressed air or oxygen shall not be used for purging refrigerant systems.

For appliances containing flammable refrigerants, refrigerant purging shall be achieved by breaking the vacuum in the system with oxygen-free nitrogen and continuing to fill until the working pressure is achieved, then venting to atmosphere, and finally pulling down to a vacuum (optional for A2L). This process shall be repeated until no refrigerant is within the system (optional for A2L). When the final oxygen-free nitrogen charge is used, the system shall be vented to the atmospheric pressure to enable work to take place. The outlet for the vacuum pump shall not be close to any potential ignition sources, and ventilation shall be available.

CHARGING PROCEDURES: In addition to conventional charging procedures, the following requirements shall be followed. Ensure that contamination of different refrigerants does not occur when using charging equipment. Hoses or lines shall be as short as possible to minimize the amount of refrigerant contained in them. Cylinders shall be kept in an appropriate position according to the instructions. Ensure that the REFRIGERATING SYSTEM is earthed prior to charging the system with refrigerant. Label the system when charging is complete. Extreme care shall be taken not to overfill the REFRIGERATING SYSTEM. Prior to recharging the system, it shall be pressure-tested with the appropriate purging gas. The system shall be leak-tested on completion of charging but prior to commissioning. A follow up leak test shall be carried out prior to leaving the site.

DECOMMISSIONING: Before carrying out this procedure, it is essential that the technician is completely familiar with the equipment and all its detail. It is recommended good practice that all refrigerants are recovered safely. Prior to the task being carried out, an oil and refrigerant sample shall be taken in case analysis is required prior to reuse of recovered refrigerant. It is essential that the electrical power is available before the task is commenced. Become familiar with the equipment and its operation. Isolate system electrically. Before attempting the procedure, ensure that mechanical handling is available, if required, for handling refrigerant cylinders; all personal protective equipment is available and being used correctly; the recovery process is supervised at all times by a competent person; recovery equipment and cylinders conform to the appropriate standards.

Pump down the system, if possible. If a vacuum is not possible, make a manifold so that the refrigerant can be removed from various parts of the system. Make sure that the cylinder is situated on the scales before recovery takes place. Start the recovery machine and operate in accordance with instructions. Do not overfill cylinders, no more than 80% volume liquid charge. Do not exceed the maximum working pressure of the cylinder, even temporarily. When cylinders have been filled correctly and the process completed make sure that the cylinders and the equipment are removed from site promptly and all isolation valves on the equipment are closed off. Recovered refrigerant shall not be charged into another REFRIGERATING SYSTEM unless it has been cleaned and checked.

LABELING DECOMMISSIONED EQUIPMENT: Equipment shall be labeled stating that it has been decommissioned and emptied of refrigerant. The label shall be dated and signed. For appliances containing FLAMMABLE REFRIGERANTS, ensure that there are labels on the equipment stating the equipment contains FLAMMABLE REFRIGERANT.

RECOVERY: When removing refrigerant from a system, either for servicing or decommissioning, it is recommended good practice that all refrigerants are removed safely. When transferring refrigerant into cylinders, ensure that only appropriate refrigerant recovery cylinders are employed. Ensure that the correct number of cylinders for holding the total system charge is available. All cylinders to be used are designated for the recovered refrigerant and labeled for that refrigerant, i.e. special cylinders for the recovery of refrigerant. Cylinders shall be complete with pressure-relief valve and associated shut-off valves in good working order. Empty recovery cylinders are evacuated and, if possible, cooled before recovery occurs. The recovery equipment shall be in good working order with a set of instructions concerning the equipment that is at hand and shall be suitable for the recovery of the flammable refrigerant. If in doubt, the manufacturer should be consulted. In addition, a set of calibrated weighing scales shall be available and in good working order. Hoses shall be complete with leak-free disconnect couplings and in good condition. The recovered refrigerant shall be processed according to local legislation in the correct recovery cylinder, and the relevant waste transfer note arranged. Do not mix refrigerants in recovery units and especially not in cylinders. If compressors or compressor oils are to be removed, ensure that they have been evacuated to an acceptable level to make certain that the flammable refrigerant does not remain within the lubricant. The compressor body shall not be heated by an open flame or other ignition sources to accelerate this process. When oil is drained from the system, it shall be carried out safely.

END USER INFORMATION

MODEL: _____

SERIAL NUMBER: _____

Date Purchased: _____

Purchased from: _____

Date Installed: _____

**For Technical Support or Service parts,
Contact our Keep Cool Team
@ 847-583-0311**

**In order to receive the benefits of our warranty,
Please register on-line at**

www.oceanaire-inc.com

OCEANAIRE-INC.COM

**1731 Wall Street, Suite 100
Phone: (847) 583-0311**

**Mount Prospect, IL 60056
Email: cs@oceanaire-inc.com**



Water
Cooled

