



PROVIDING A BETTER CLIMATE ANYWHERE.

# OWC2412QC

## 2 Ton Deluxe Portable Water-Cooled Spot Cooler with Quick Connect

---

ENGINEERING, INSTALLATION AND SERVICE MANUAL



WATER COOLED

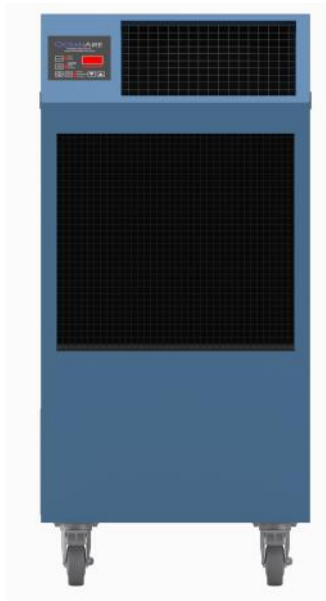

*Cooling done Right!*



[oceanaire-inc.com](http://oceanaire-inc.com)

1731 Wall Street, Suite 100

Mount Prospect, IL 60056

Phone: (847) 583-0311

Fax: (847) 583-0312

# TABLE OF CONTENTS

	<b>PAGE</b>
<b>GENERAL INFORMATION</b> .....	1
<b>PRODUCT DATA AND SPECIFICATIONS</b> .....	2
<b>UNIT DESCRIPTION</b>	
Standard Features.....	3
Applications, Electrical Configuration.....	4
Unit Interior.....	5
Installation Instructions.....	6
Accessories.....	7–8
Hose Kits.....	9
Hose Kit Installation Instructions.....	10
Optional Hose Adapter Kit.....	11
<b>SERVICE</b>	
Thermostat/Controller Operation.....	12–14
Water Valve Adjustment.....	15
Replacement Parts Procedure.....	16
Troubleshooting Guide.....	17
Preventive Maintenance.....	18
<b>DIAGRAMS</b>	
Piping Schematic.....	19
Wiring Diagram.....	20
<b>WARRANTY</b> .....	21
<b>END USER INFORMATION, TECH NOTES</b> .....	Back Page

## FORWARD

This manual provides the user with basic details for the installation and operation of the Oceanaire OWC2412QC spot cooler. It is recommended to read and fully understand the instructions outlined within this manual, before operating the OWC2412QC unit.

As with all commercial air conditioning equipment, it is recommended to have the OWC2412QC sized and installed by a licensed specifying engineer and contractor, in accordance with all local and state codes. The length of service received can be extended by following the installation and preventive maintenance instructions.

## NOTICE

In our ongoing process of continuous improvement, the items and procedures described in this manual are subject to change without notice. Please note model and serial number of the OWC2412QC unit when contacting the factory.

# **GENERAL INFORMATION**

The OceanAire OWC2412QC is a portable water-cooled air conditioner designed for permanent or temporary spot cooling applications. The entire air conditioning unit has been built in an attractive sheet metal cabinet, equipped with heavy-duty casters for mobility. All OWC2412QC models come with a 10-foot power cord for electrical connection and added mobility in service. These spot-coolers are designed to direct air to specific areas or objects through a discharge grille located on the upper-front of the unit.

The OWC2412QC is a self-contained unit with the entire cooling system (blower assembly, electrical, refrigerant, and water side components), neatly arranged in a gray and blue polyester powder coated metal cabinet. When connected to the proper source of electrical power, the OWC2412QC is controlled by a solid-state electronic device, with numerous options of temperature and airflow controls that will provide the desired level of comfort and cooling.

A wide variety of accessories and factory installed options are available for the OWC2412QC, allowing for improved performance and versatility.

## **NOMENCLATURE**

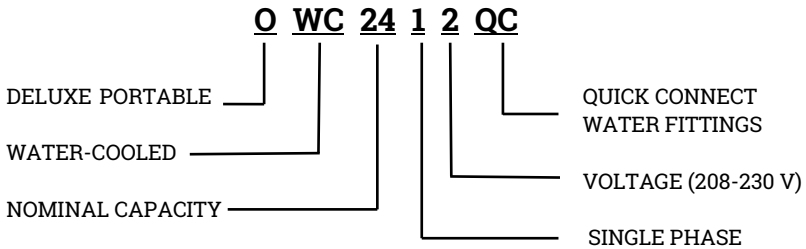

## **CAPACITY RATING**

OWC2412QC.....24,000 BTU/HR

**NOT APPROVED FOR OUTDOOR USE**

## **WARRANTY**

ALL OCEANAIRE PRODUCTS ARE COVERED BY THE  
OCEANAIRE LIMITED WARRANTY  
**1 YEAR ON THE FULL PRODUCT**  
PLUS, 4 ADDITIONAL YEARS FOR THE COMPRESSOR  
(Restrictions Apply)

## **WARRANTY CARD**

It is important that the warranty card be filled out completely and returned to the factory within fourteen (14) days of installation of the unit in order to receive the benefits of the warranty.

# SPECIFICATIONS

# OWC2412QC

<b>COOLING CAPACITY</b>	<b>24,000 btu/hr</b>
VOLTAGE	208-230 V, 60Hz, 1PH
AMPS	9.9
WATTS	2100
IN RUSH AMPS	655
PLUG TYPE	6-20P, LCDI
EER	11.4
COMPRESSOR	ROTARY
COMPRESSOR HP	2
COMPRESSOR LRA	48
EVAP CFM	810
EVAP MOTOR HP	1/83
COND GPM at EWT, 60°F	1.5
COND GPM at EWT, 85°F	6.0
<b>QUIC CONNECT WATER LINE CONNECTIONS</b>	
WATER IN	3/8"
WATER OUT	3/8"
DRAIN	1/4"
CONDENSATE REMOVAL LIFT (VERTICAL)	PUMP—AUTOMATIC 20 FT
REFRIGERANT	16 oz R-410A
HEIGHT	45.7 in
WIDTH	21.5 in
DEPTH	16.0 in
NET WEIGHT	170 lb.



## SPECIFICATIONS SUBJECT TO CHANGE WITHOUT NOTICE

- QA Cooling capacity is total BTUH at 80°DB/67°WB return air, High fan speed, with 85°EWT to 95°LWT (6.0 GPM)
- QA Time delay fuses/circuit breakers are recommended
- QA EER is determined at High fan speed
- QA CFM with free discharge
- QA Amps and Watts at 230 volts
- QA Hose colors
  - Water in—black label (3/8)
  - Water out—red label (3/8)
  - Drain—yellow label (1/4)



**COOLING AMBIENT OPERATING RANGE 65° to 105°**

**NOT APPROVED FOR OUTDOOR USE**

# STANDARD FEATURES

## CABINET

The OWC2412QC cabinet is constructed of 18 gauge steel with a gray and blue polyester powder coated finish that will compliment any decor. The entire cabinet is insulated with sound-absorbing insulation for cool, quiet comfort. All units come equipped with swivel casters for portability and convenient set-up.

## DELUXE ELECTRONIC CONTROLLER

The OWC2412QC is equipped with a deluxe electronic controller. When proper power is connected to the unit, the thermostat will control the unit to cool a space to the desired temperature. The thermostat is also capable of controlling the fan to operate automatically (when needed) or continuously. To protect the compressor from short-cycling, there is a built-in time delay in the thermostat. In the event of a power outage, all thermostat settings are saved, and the unit will re-start automatically.

## FAN SPEED CONTROL

The deluxe electronic controller is capable of setting the fan speed for manual or automatic. In manual setting, the fan speed can be programmed to any of the six fan speed levels, from (1) Low to (6) High. In auto setting, the unit will determine the best fan speed based on the inside temperature and selected SETPOINT.

## CONDITION ALARM—CON

The LED thermostat of the unit will display the fault "CON" which indicates a condition that needs to be addressed.

CONDENSATE PUMP... Failed/Restricted drain tube/routed incorrectly

WATER SUPPLY..... Turned off/Interrupted flow

***EITHER CONDITION WILL DISABLE THE COMPRESSOR***

## CONDENSATE PUMP

Each OWC2412QC unit comes equipped with an Automatic Condensate Pump that removes the condensate. The pump discharges through a check valve located on top of the condensate pump assembly. The vinyl tubing exits through a 3/8" flare connection, located in the recessed area on the right side of the unit. The pump has capabilities up to a 20' lift, to handle almost any installation requirement. If a failure occurs with the operation of the pump circuit, the **Normally Closed overflow switch** will open, and the fault "CON" will display in the window. When the failure has been corrected, or the condensate line blockage/kink has been resolved, the fault will be dropped from the screen, and the unit will restart.

## HIGH PRESSURE SAFETY SWITCH

Located in the recessed area of the OWC2412QC unit is a manual reset high pressure switch. It is used for the protection of the compressor, in the event that the condenser water supply is turned off. If the internal pressure exceeds the limit setting, the switch cycles off the compressor, while the evaporator fan continues to operate. Once the water interruption has been corrected, turn the unit off, **RESET THE RED BUTTON** by pushing down on the rubber boot in the recessed area of the unit, listening for the click, and restart the unit.

## FILTERS

The OWC2412QC unit is equipped with a washable filter at the air intake. An electrostatic mesh air filter is located behind the evaporator return air grille to filter the air before it is cooled, keeping the coil free from dust build-up. The filter can be easily removed and cleaned.

## POWER CORD

The OWC2412QC unit is equipped with a 10 foot (6-20P) power cord for convenience, and has a LCDI device for added safety.

# APPLICATIONS

## SPOT COOLER

The OWC2412QC can be used in an open environment to cool specific objects or "spots". Spot Cooling is a convenient and economical way to provide air conditioning where cooling the entire space is not viable. Cool air is discharged from the units grille and is directed where it is needed. A nozzle kit can be used to improve the velocity.

## ROOM AIR CONDITIONER

One feature of the OWC2412QC is it operates as a room air conditioner because water is used as the means for heat rejection. The major advantage of water-cooled air conditioning is the convenience of connecting water hoses, or lines, as compared to the installation of condenser air ducts used for air-cooled portables. A variety of hose kit lengths are available that can be used for connecting to a water supply and drain, while providing portability within the conditioned space.

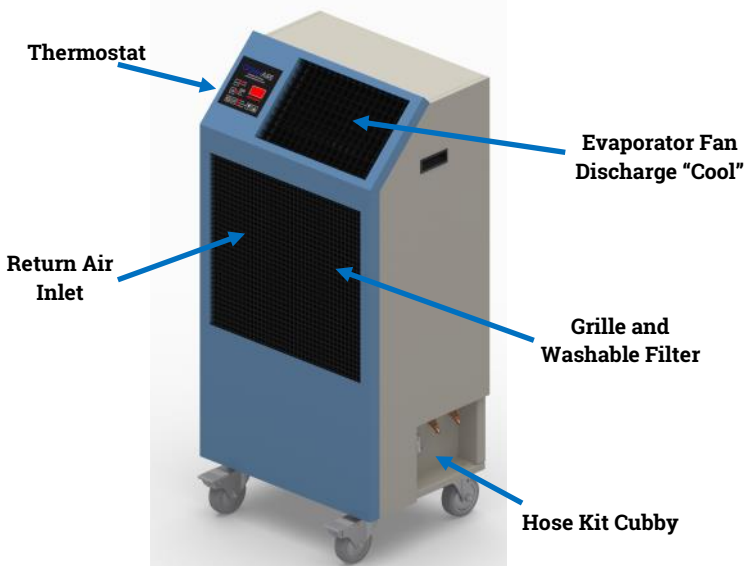

## ELECTRICAL CONFIGURATION

The OWC2412QC unit is equipped with a standard 10-foot service cord which has a 6-20P plug configuration. The molded LCDI (Leakage Current Detection & Interruption) device serves as a means of electrical protection.

UNIT/MODEL	PLUG CONFIGURATION	RECEPTACLE
<u>208-230 VOLT</u> OWC2412QC	 20A-240 VOLT NEMA 6-20P	NEMA 6-20R

**CAUTION: DO NOT USE THE LCDI AS AN ON/OFF SWITCH FOR THE UNIT**

# OWC2412QC INTERIOR

**Motor**



**Thermostat**

**Blower Wheel**



**Compressor**

**Evaporator Coil**

**High Pressure Switch Reset Button**



**Cubby for the Hose Kit**

**Condensate Pump**

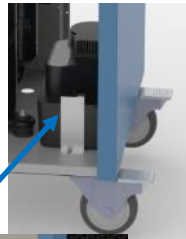

**Condensate Pump Access Door**

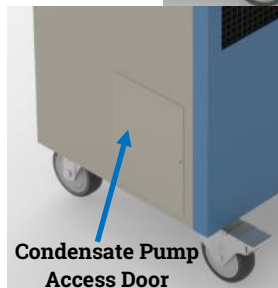

# **INSTALLATION INSTRUCTIONS**

## **RECEIVING—INSPECTION**

Upon receiving your unit, inspect the packaging for any damage. All units are shipped on a skid, and packaged in a triple-wall carton for added protection.

## **BEFORE INSTALLING**

Check the unit for any damage. All Oceanaire products are thoroughly inspected at the factory and carefully packaged. If any damage is evident, contact Oceanaire **IMMEDIATELY**.

## **ELECTRICAL REQUIREMENTS**

Check the nameplate located on the back of the unit to confirm the proper power is available for the unit. Refer to "**Specifications**" section for voltage and amperage requirements. For the proper NEMA receptacle, refer to "Electrical service plug configuration". When using an extension cord, use the proper gauge cord, and check cord voltage at the unit.

## **TIME DELAY FUSES/CIRCUIT BREAKERS ARE RECOMMENDED**

### **WARNING—OPERATING THE UNIT ON IMPROPER VOLTAGE WILL VOID THE WARRANTY**

### **CAUTION**

**AN EXTENSION CORD CAN BE USED PROVIDED IT IS RATED AT LEAST 15 AMPS  
@ 115 VOLTS WITH GROUNDING-TYPE ATTACHMENT PLUG AND GROUNDING  
TYPE CONNECTOR (LOAD FITTING)**

**A DAMAGED LCDI POWER SUPPLY CORD MUST BE REPLACED  
WITH A NEW POWER SUPPLY CORD OBTAINED FROM  
OCEANAIRE, AND NOT REPAIRED**

## **ACCESSORIES**

Verify that all accessories are correct for the model, and are installed in accordance with all instructions.

## **START-UP**

Install the unit in accordance with all local and state building codes, and install all accessories. Allow for a clearance around the unit for future maintenance and/or service. Level unit and lock casters. Connect power and test the LCDI on the power cord. Power up unit via thermostat, and check for proper operation. Refer to Thermostat Operation for more details.



# OWC2412QC ACCESSORIES

## DISCHARGE AIR NOZZLE KIT ASSEMBLY



**2NK-2**  
**(2 X 6") NOZZLE KIT**  
for Directional Cooling

An optional discharge nozzle kit is used to direct the conditioned air to a specific target area. By concentrating the airflow, the nozzles increase the air velocity towards production lines to cool personnel and/or equipment. In server rooms, the nozzles can be used to direct the airflow through the rack to remove the heated air from the equipment.

**2NK-2 for model OWC2412QC** with (2) 6-inch diameter nozzles with an approximate compressed length of 22". The approximate extended length is 32".

The nozzle kit comes pre-assembled with the nozzles secured to a mounting plate, and include edge guards. By removing the OWC2412QC discharge grille, the nozzle kit can then be installed in the grille opening.

## EVAPORATOR RETURN AIR PLENUM

Evaporator return air plenum is available for installations where it is required to duct the return air to the inlet of the evaporator. The evaporator return air plenum allows the user to connect round duct (flexible or rigid) to the return air intake to reduce air noise and increase the number of options for solving difficult cooling problems. The plenum attaches to the front of the unit, replacing the return air grille.

**2DEP-12 for OWC2412QC** transitions the return opening to a **12-inch round duct**.

**NOTE—When a 2DEP-12 is installed, it is recommended to set the evaporator blower speed to high, to avoid evaporator coil freeze-up.**

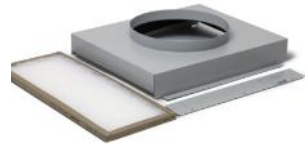

**2DEP-12**  
**EVAPORATOR RETURN AIR PLENUM**  
for Ducting Return Air

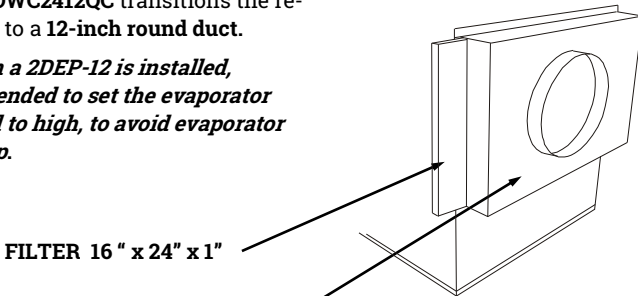

**EVAPORATOR RETURN AIR PLENUM**

# OWC2412QC ACCESSORIES

## DISCHARGE DUCT ADAPTER

A discharge duct adapter is available for applications where ducting the cool air is required. The adapter can be easily installed on the unit without fasteners, and be installed for either vertical or horizontal ducting. The standard discharge grille is removed and the DDA is placed in the grille opening.

**2DDA-10** for OWC2412QC, converts the evaporator discharge to a 10-inch diameter round duct.

When used in conjunction with the evaporator return air plenum, 2DEP-12, the unit can provide closed-loop cooling to and from a given space without the influence of any outside air.

***NOTE***—When a 2DDA-10 is installed, it is recommended to set the evaporator blower speed to high, to avoid evaporator coil freeze-up.



**2DDA-10**

# HK-QC SERIES HOSE KIT

All Oceanaire hose kits are designed for use with Oceanaire Portable Water-cooled Air conditioners, to accommodate almost any installation requirement. The hose kit allows for the unit to be connected to a water source while providing a certain level of portability and ease of installation. The HK Hose kits are available in three lengths; **10-foot, 25-foot and 40-foot.**

The hose kit consists of three separate hoses; WATER IN (3/8), WATER OUT (3/8) and DRAIN (1/4). The **WATER-IN (BLACK)** and **WATER-OUT (RED)** hoses are made of reinforced PVC tubing and serve for the water supply and water return. The **DRAIN (YELLOW)** is made of gray PVC and is used for the condensate pump discharge to a drain.

A QC lanyard is supplied with each QC Coupling. When engaged, this device releases the internal valve of the coupling allowing for air to break the vacuum and drain the hose.

## MAXIMUM WORKING PRESSURE FOR WATER LINES: 100 PSIG



FEATURE	WATER-IN HOSE WATER-OUT HOSE	CONDENSATE HOSE
Material	PVC with Polyester Braid	Gray PVC
ID, Wall Thickness	3/8 ID, 0.219 Wall	1/4 ID, 0.063 Wall

### UNIT SIDE FITTINGS TERMINATION FITTINGS

HOSE KIT PART NO.	For Use with OWC	WATER IN	WATER OUT	DRAIN	HOSE KIT LENGTH	WATER SUPPLY	WATER- OUT	DRAIN
<b>HK-1QC</b>	24	3/8 QC Coupling	3/8 QC Coupling	1/4 QC Coupling	<b>10 ft.</b>	3/4 Female Hose Conn*	No Fitting	No Fitting
<b>HK-2QC</b>	24	3/8 QC Coupling	3/8 QC Coupling	1/4 QC Coupling	<b>25 ft.</b>	3/4 Female Hose Conn*	No Fitting	No Fitting
<b>HK-5QC</b>	24	3/8 QC Coupling	3/8 QC Coupling	1/4 QC Coupling	<b>40 ft.</b>	3/4 Female Hose Conn*	No Fitting	No Fitting

# HK-QC INSTALLATION INSTRUCTIONS

1. Connect Hose Kit to unit by aligning the QC Coupling with the QC Fitting on the unit. Connect the hose kit according to hose and unit labels: BLACK to WATER IN, RED to WATER OUT and YELLOW to DRAIN. HOLD the coupling behind the sleeve allowing the sleeve to move freely and PRESS firmly, until the sleeve retracts and clicks. The "click" means that the QC Coupling is engaged onto the QC Fitting.
2. Connect WATER IN hose to water supply using hose connection, and sink adapter (if needed).
3. Install WATER OUT line in drain, allowing for free drain conditions with an air space around the opening.
4. Install DRAIN line in drain, allowing for free drain conditions.
5. Open water supply valve, and check for any water leaks in hose connections.

To release the coupling, Hold the Coupling as shown below, and pull back on the sleeve. The Coupling will release and the valve inside of the coupling seal.

**Once off-site, use the fitting secured to the hose kit by the lanyard to break the vacuum, and drain the hoses.**

## High Pressure Switch Reset Button

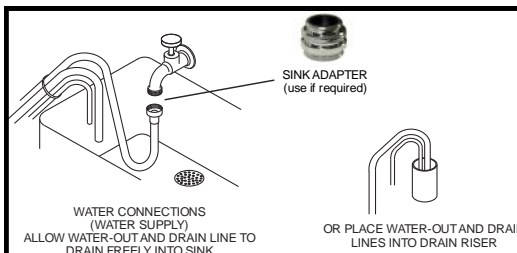
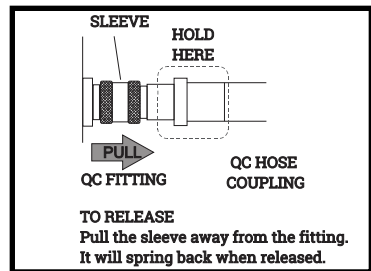
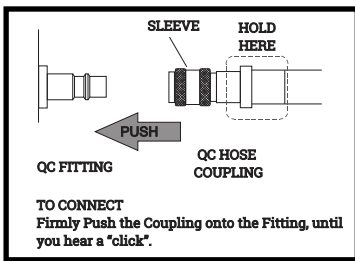
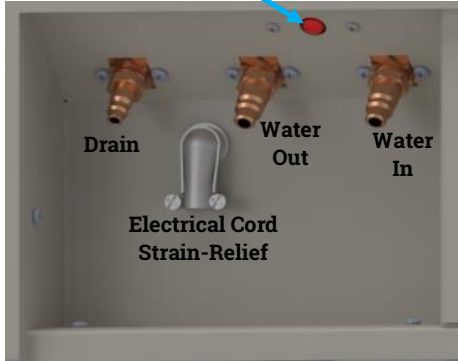

# HA-SMQC HOSE ADAPTER KIT



The **HA-SMQC Hose Adapter Kit** allows for the installation of a QC water cooled unit where the Standard QC Hose Kit cannot accommodate the installation. The kit provides a means of connecting hoses to a QC-Model unit when the water source and drain are located in separate areas, or where longer hose runs are desired. The HA-SMQC Hose Adapter is equipped with Quick-Connect Couplings along with the Garden Hose Connections as shown below:

FEATURE	WATER-IN HOSE WATER-OUT HOSE	CONDENSATE HOSE
Material	PVC with Polyester Braid	Gray PVC

HOSE KIT PART NO.	For Use with	UNIT SIDE FITTINGS				LENGTH	TERMINATION FITTINGS		
		WATER IN	WATER OUT	DRAIN	WATER SUPPLY		WATER- OUT	DRAIN	
<b>HA-SMQC</b>	OWC2412QC	3/8 QC Coupling	3/8 QC Coupling	1/4 QC Coupling	<b>2 ft.</b>	3/4 Female Garden Hose	3/4 Male Garden Hose	3/8 Hose Barb	

# DELUXE ELECTRONIC CONTROLLER

The OWC2412QC controller is equipped with many features for a more precise level of cooling and operation. With the addition of a remote sensor, the controller can sense temperatures in another space or in ductwork. Doing that, you over-

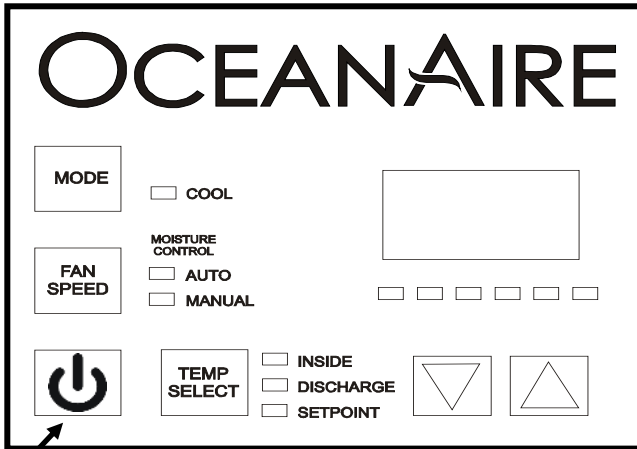

POWER  
BUTTON

## OCEANAIRE DELUXE ELECTRONIC CONTROLLER

When power is connected, the controller will display "888" momentarily, and then disappear. Press the POWER button, then scroll down to the TEMP SELECT button until the SET POINT is displayed. Adjust the SET POINT to the desired temperature, and the unit will cool as required.

### **The systems controls temperature within +/- 2°**

**POWER**—Turns the unit on/off when power is supplied

**MODE** - Selects the mode of operation between Cool and Moisture Control.

**COOL** - The system will operate in cooling mode only.

**MOISTURE CONTROL** - The system operates in the cooling mode to reduce humidity within the conditioned space.

Every 4 hours, the fan is started, circulating the air, and the air temperature is recorded by the controller. The cooling cycle is started for one hour, or until the room temperature drops 2°, which ever comes first. This cycle repeats every four hours.

**FAN SPEED**—The operator can select between **AUTO** or **MANUAL** fan speed control. Pressing the **FAN SPEED** button will switch speed from **AUTO** to **MANUAL**. In **MANUAL** mode, pressing the **FAN SPEED** button will change fan speed from low (1) to high (6). In **AUTO** mode, the fan speed is controlled automatically. In cooling mode, the controller automatically adjusts the fan speed to high, and as the inside temperature approaches the set point, the fan speed will decrease.

**TEMP SELECT**— Allows the operator to view the controller temperatures

**INSIDE** = return air temperature, **DISCHARGE** = supply air temperature,

**SET POINT** can be seen and adjusted, by pressing ▲ or ▼

# CONTROLLER PROGRAMMING MENU

- 1) Make sure the unit has power .
- 2) Press the power  button "OFF".
- 3) Press the following buttons in sequence "S-U-D-S"  
(Select-Up arrow - Down arrow - Select)
- 4) The display will begin flashing P1 and a number.

*If there is no display, repeat the sequence,  
making sure the unit has power, but is turned OFF.*

- 5) To adjust any program feature, press the **ARROW UP ▲** or **ARROW DOWN ▼** button until the desired value is displayed.
- 6) Use the "MODE" button to scroll through the programmable settings P1 through P16.
- 7) If no buttons are pressed, the display will then return to the "OFF" position after about 50 seconds.



**PROGRAM**

## **SETTINGS**

- P1-High Fan Speed Limit Setting: 56 - 85**
- P2-Low Fan Speed Limit Setting: 30 - 55**
- P4-Temperature Sensor Calibration: +/- 10°**
- P10- Temperature Display: °F or °C**
- P13-Supply Fan Operation: Cycling or Continuous**

**P1, P2** - To adjust fan speed settings, **P1** represents the high fan speed parameter, while **P2** represents the low fan speed parameter. When using nozzle kits, discharge duct adapters and evaporator plenums, setting **P1** to 85 will help to avoid freeze ups.

**P4** - Adjust the **P4** setting to match the actual INSIDE room temperature, if needed.

**P10** - Use this parameter to display temperatures in the desired units.

**P13** - To cycle the evaporator fan with the compressor, access code **P-13**. Press the up or down button to switch to "CYC", which means cycle the fan with the compressor. The factory default setting is "CON", which means continuous fan operation.

- 8) Press **POWER** - you should see an alphanumeric code.

Press **POWER** and the unit will start at the new settings

# OWC2412QC PROGRAM SETTINGS

MODEL	CODE SETTINGS
OWC2412QC	P1 = 70, P2 = 50

## NOTICE

**Program Parameters are NOT controller default values.  
They are Oceanaire Factory Settings**

## DISPLAY FAULTS

**LAC**..... Low AC line power

**AAA or - - -** ..... Failed Air Sensor (unit will not run)

**CON**..... Failed Condensate Pump/Over-Flow Alarm  
High Pressure Cut-Out—Low/interrupted condenser  
water supply. Correct problem, and re-set unit at  
HP RESET

## TO CHECK THE NUMBER OF HOURS ON THE UNIT

- 1) Disconnect unit power, and reconnect unit power.
- 2) When "888" appears in display, push and release the arrow down button

3) The first set of numbers displayed reads thousands of hours:  
02 = 2000, 04 = 4000 hours, 00  means less than 1000 hours.

4) The second set of numbers read hours directly:  
58 = 58 hours. 742 = 742 hours.

6) Add the 2 number sets together to get total hours.  
03 and 486 = 3486 hours.  
01 and 59 = 1059 hours.

**TOTAL HOURS REPRESENTS COMPRESSOR "RUN" TIME**



# WATER VALVE ADJUSTMENT

Each OCEANAIRE WATER-COOLED unit is equipped with an automatic water regulating valve to control the condenser water flow rate. The water valve will open when the unit is in the cooling mode and adjust the gallon per minute flow rate based on the entering water temperature (EWT).

The water valve operates independently from the water system, and regulates flow based on the systems refrigerant head pressure.

Under certain conditions, entering water temperatures can cause the valve to rapidly open and close, causing a “harmonic” pitch in the water supply line. In these cases, it is recommended that the water valve be adjusted.

1. Disconnect the unit power.
2. Remove water valve cover plate or back panel (depending on model) to locate the water valve.
3. At the top of the valve, there is a square shaped adjustment screw. Using a standard service wrench or flat blade screwdriver, adjust the valve using quarter turns, allowing the unit to operate approximately 5 minutes after each new setting.
  - CLOCKWISE (CW) to lower the system head pressure opening point.
  - COUNTER-CLOCKWISE (CCW) to raise the system head pressure opening point.
4. Re-install cover plate (or back panel) when finished.

**Water Valve**



**Water Valve Cover Plate**



# OWC2412QC

## REPLACEMENT PARTS PROCEDURE

IT IS RECOMMENDED THAT ALL OCEANAIRE UNITS  
BE SERVICED BY A LICENSED TECHNICIAN

***WARNING—TO AVOID INJURY, DISCONNECT UNIT POWER PRIOR TO SERVICING***

### **A. FAN MOTOR**

1. Remove rear panel and cabinet left-side panel (when looking at the front of the unit).
2. Evaporator blower wheel –disconnect evaporator motor wires from run capacitor and power module (L1/L2).
3. Remove the screws securing motor and inlet-ring to blower housing (all screws are external and visible), and remove blower wheel-motor assembly. Remove the blower wheel set screw and disassemble the blower wheel from the motor shaft and remove the motor.
4. Install the new components, reversing the removal procedure.

### **B. ELECTRONIC CONTROLLER (THERMOSTAT)**

To replace cooling thermostat, remove left side panel to access controller assembly. Using a 5/16" nut driver, remove (2) nuts on threaded studs, unplug the display cable, and lift up to remove the controller. Plug display cable in the new controller, and secure in place.

### **C. POWER MODULE**

To remove the power module, remove the rear control box cover. Disconnect wires (one at a time), and re-attach each wire, while holding replacement module in other hand. Once all wires have been reconnected in accordance with the wiring diagram, install new power module.

### **D. CONDENSATE PUMP**

1. Remove condensate pump access panel.
2. Remove brackets securing condensate pump in base pan.
3. Disconnect pump wire leads at Molex connectors. Remove retainer clamp and tubing.
4. Replace pump, install by reversing procedure.

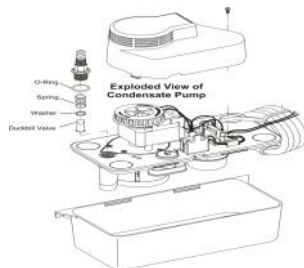

### **E. HIGH PRESSURE SAFETY SWITCH**

1. Remove cabinet rear panel.
2. Remove flare nut that secures capillary to the refrigeration system high pressure side. A schrader valve is located in the discharge port which allows removal without losing the refrigerant charge.
3. Remove two screws that secure high pressure switch.
4. Disconnect wire leads from power module and condensate pump safety switch.
5. Install new High Pressure Switch, and splice in new wire leads with existing control wires. Then reverse in order to complete procedure.

***To gain access to compressor and compressor run capacitor, remove left hand side panel.***

# **TROUBLESHOOTING GUIDE**

The following steps and procedures are recommended for correcting the problems indicated. In the event that the problem can not be corrected, service may be required.

## **SERVICE SHOULD BE PERFORMED BY A QUALIFIED AIR CONDITIONING SERVICE TECHNICIAN**

### **PROBLEM: UNIT DOES NOT POWER UP**

**CAUSE:** Power interruption

**REMEDY:** Check LCDI and reset. Check external power supply making sure that the disconnect is ON. Check for blown fuses or tripped circuit breakers. Reset or replace (as needed).

### **PROBLEM: NO DISPLAY ON THERMOSTAT AFTER POWER "ON"**

**CAUSE:** Loose display cable, faulty thermostat or faulty power module

**REMEDY:** Check display cable, re-seat connectors. Thermostat may be defective...remove and replace. Power module may be defective...remove and replace.

### **PROBLEM: EVAPORATOR FAN RUNS BUT COMPRESSOR DOES NOT START**

**CAUSE:** Thermostat – set point is too high.

**REMEDY:** Make sure set-point is lower than room temperature. Look for a red dot to the right of the temperature displayed for cooling.

#### **Note—there is a time delay for the compressor**

**CAUSE:** Thermostat—Loose display cable

**REMEDY:** Examine the thermostat for a loose cable connection. Re-seat the display cable from thermostat to power module.

**CAUSE:** Condensate Alarm—"CON" is displayed.

**REMEDY:** Check condensate pump and make sure pump is working properly and that there is no kink in the drain line from the pump.

**CAUSE:** High Pressure Cut-Out—"CON" is displayed. Inadequate/turned off condenser water supply.

**REMEDY:** Verify condenser water supply. Check High Pressure Cut-Out Switch. Press Reset (RED Button in recessed cubby). Re-start unit.

**CAUSE:** Low Voltage – "LAC" is displayed. Check power supply for voltage outside the range of 187-253 volts.

**REMEDY:** Have power checked by electrician and repaired.

**CAUSE:** Compressor relay failure...fan relay failure

**REMEDY:** Replace power module.

# **PREVENTIVE MAINTENANCE**

OWC2412QC is designed to last a long time and to give maximum performance and reliability with minimum maintenance. To prolong the life of the unit, regular maintenance must be performed as specified below:

## **OFF SEASON STORAGE – WINTERIZATION**

Before placing the unit into storage for the off-season, it is recommended to thoroughly clean the unit, and remove all water in the CONDENSER COIL, WATER LINES, DRAIN PAN and CONDENSATE PUMP to avoid damage to the unit from freezing water or contamination.

## **DRAINING THE CONDENSER COIL, AND INTERIOR WATER LINES**

To drain the condenser coil, detach the WATER IN and WATER OUT lines. Using a Shop-Vac or similar device, vacuum the WATER OUT line and start the unit. The water valve will open, allowing you to vacuum the water out of the condenser coil. Eventually, the High Pressure Cut-Out will shut down the compressor. Wait 15 minutes, depress the HI PRESSURE RESET and repeat this process until ALL of the water is out of the system. When completed, depress the HIGH PRESSURE RESET one final time to make sure that it is reset.

## **DRAINING THE HOSE KIT**

To drain the hose kit, disconnect all hoses, and allow the hoses to gravity drain.

## **EVACUATING THE CONDENSATE PUMP**

Using a Shop-Vac or similar device, vacuum all water out of the condensate pump reservoir. Condensate pumps come standard on all OWC models. When servicing pump, follow these steps:

1. Make certain that the unit is disconnected from the power source before attempting to service or remove any component.
2. Be sure the floats move freely. Clean as necessary.
3. Remove the pump assembly and check for obstructions. Clean as needed.
4. Clean the reservoir with warm water and mild soap when mineral deposits are visible.
5. Check the inlet and outlet piping. Clean as necessary. Be sure there are no kinks in the lines that would inhibit flow.

## **CLEANING THE UNIT**

Wash all coils and filters and allow the unit to dry completely.

## **BLOWER MOTOR**

The evaporator motor on all units have permanently lubricated bearings. No oiling is Necessary.

## **FILTER**

A clogged filter will cause the unit to operate at greatly reduced efficiencies. We recommend that the filter be inspected on a regular basis (**every six weeks or less**) depending on the environment. The evaporator filter is located behind the return air grille and can be easily removed and cleaned. The filter must be washed periodically as needed by placing it in a dishwasher or soaking in a solution of warm water and detergent for 10 minutes. Then rinsing clean with hot water and shaking excess moisture from filter.

## **GENERAL**

**Oceanaire products are NOT approved for outdoor use.** Therefore, off-season storage should be indoor, protected from weather conditions.

*When necessary maintenance steps outlined above are followed, the air conditioner will provide long and reliable service. The refrigeration and electrical circuits of the system should only be serviced by a fully qualified service technician.*

# PIPING SCHEMATIC

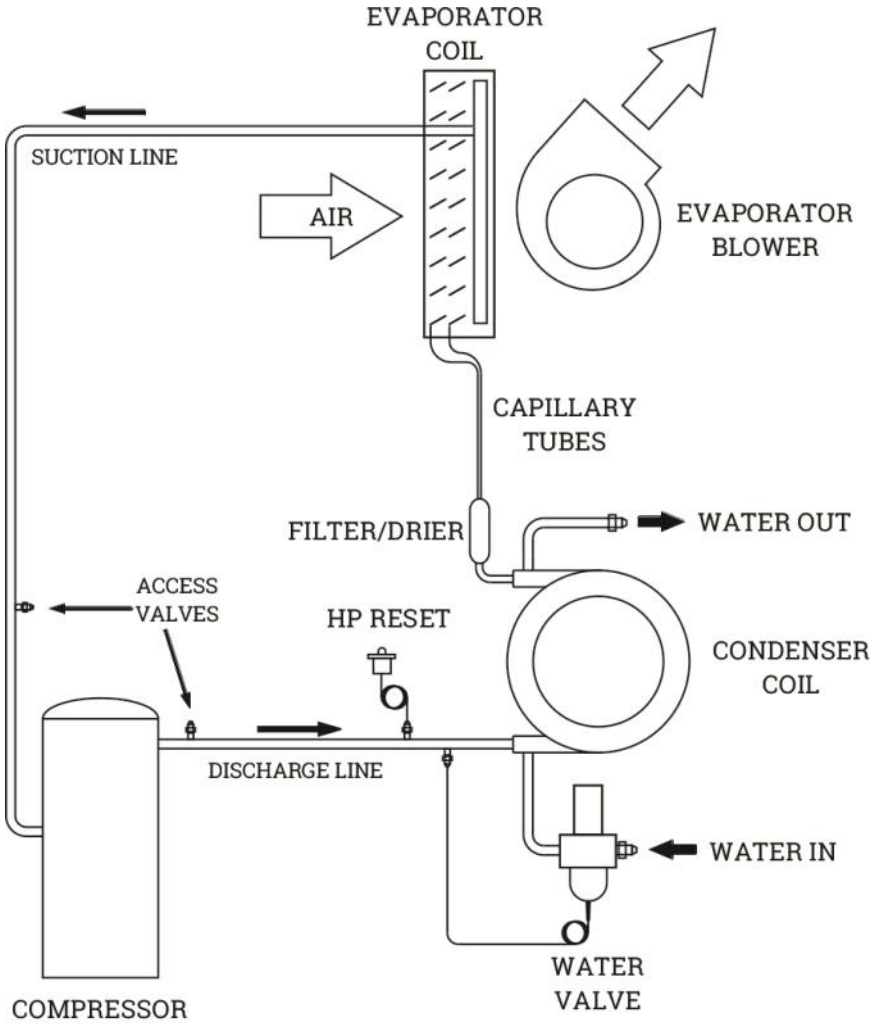

**PIPING SCHEMATIC**  
**Water-Cooled Spot Cooler**

# WIRING SCHEMATIC FOR OWC2412QC

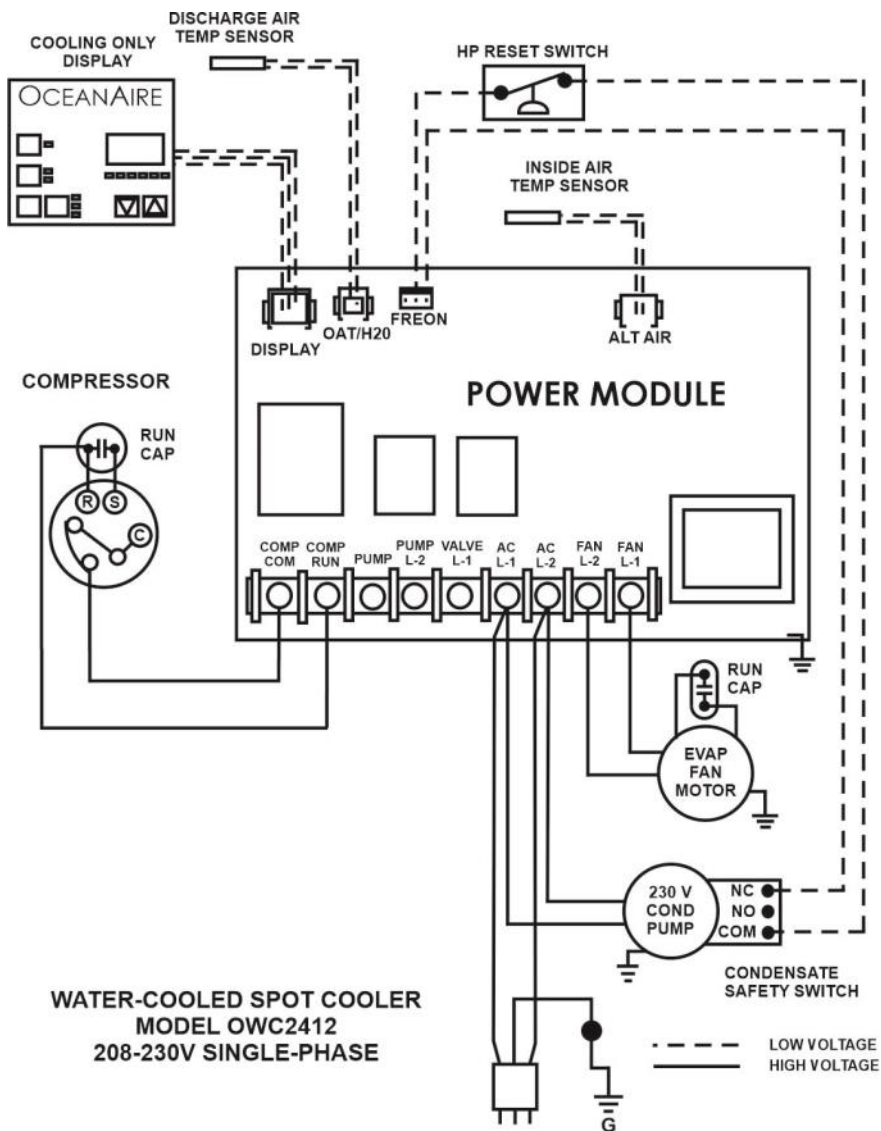

## LIMITED WARRANTY

The Manufacturer (Oceanaire, Inc.) warrants to the original owner that the Product will be free from defects in material or workmanship for a period not to exceed one (1) year from date of installation. If upon examination by the Manufacturer, the Product is shown to have a defect in material or workmanship during the warranty period, the Manufacturer will repair or replace, at its option, that part of the Product which is shown to be defective.

The Manufacturer further warrants that the product's compressor-motor will be free from defects in materials and workmanship for five (5) years from the date of installation.

If upon examination by the Manufacturer the Product is shown to have a defect in materials or workmanship during the warranty period, the Manufacturer will repair or replace, at its option, that Part of the Product which is shown to be defective.

***Compressor warranty shall be pro-rated for years 2 – 5 at the sole discretion of Oceanaire.*** Electrical parts such as relays, overloads, capacitors, etc., and the sealed refrigeration system (condenser and evaporator) are included in the one year limited warranty, but not with the five year limited warranty of the compressor.

This limited warranty does not apply to:

- a) Product that has been subjected to misuse or neglect, has been accidentally or intentionally damaged, has not been installed, maintained or operated in accordance with the furnished written instructions, or has been altered or modified in any way.
- b) Product that has been subjected to any abnormal power conditions such as loss of power, power surges, voltage irregularities such as brown-outs or phase loss on three-phase equipment).
- c) any expenses, including labor or material, incurred during removal or reinstallation of the Product.
- d) any workmanship of the installer of the Product.

This limited warranty is conditional upon:

- a) return to the Manufacturer, of the part of the Product thought to be defective. Goods can only be returned with prior written approval from the Manufacturer. All returns must be freight prepaid.
- b) determination in the reasonable opinion of the Manufacturer, that there exists a defective in material or workmanship.

Repair or replacement of any part under this Limited Warranty shall not extend the duration of the warranty with respect to such repaired or replaced part beyond the stated warranty period.

THIS LIMITED WARRANTY IS IN LIEU OF ALL OTHER WARRANTIES, EITHER EXPRESSED OR IMPLIED, AND ALL SUCH OTHER WARRANTIES, INCLUDING WITHOUT LIMITATION IMPLIED WARRANTIES OF MERCHANTABILITY OR FITNESS FOR A PARTICULAR PURPOSE, ARE HEREBY DISCLAIMED AND EXCLUDED FROM THIS LIMITED WARRANTY. IN NO EVENT SHALL THE MANUFACTURER BE LIABLE IN ANY WAY FOR ANY CONSEQUENTIAL, SPECIAL, OR INCIDENTAL DAMAGES OF ANY NATURE WHATSOEVER, OR FOR ANY AMOUNTS IN EXCESS OF THE SELLING PRICE OF THE PRODUCT OR ANY PARTS THEREOF FOUND TO BE DEFECTIVE. THIS LIMITED WARRANTY GIVES THE ORIGINAL OWNER OF THE PRODUCT SPECIFIC LEGAL RIGHTS. YOU MAY ALSO HAVE OTHER RIGHTS WHICH MAY VARY BY EACH JURISDICTION.

## END USER INFORMATION

MODEL: \_\_\_\_\_

SERIAL NUMBER: \_\_\_\_\_

Date Purchased: \_\_\_\_\_

Purchased from: \_\_\_\_\_

Date Installed: \_\_\_\_\_

For Technical Support or service parts,  
contact our **Keep Cool Team**  
at **847-583-0311**

In order to receive the benefits of our warranty,  
please register on-line at  
**[www.oceanaire-inc.com](http://www.oceanaire-inc.com)**



*Cooling done Right!*



[oceanaire-inc.com](http://oceanaire-inc.com)

1731 Wall Street, Suite 100      Mount Prospect, IL 60056  
Phone: (847) 583-0311      Fax: (847) 583-0312