

OCEANAIRE

MODEL: 2OACH6034
5 TON DELUXE PORTABLE HEAT PUMP

TECHNICAL SPECIFICATIONS

COOLING CAPACITY	60,100 BTUH
HEATING CAPACITY	53,500 BTUH
VOLTAGE	460V, 60Hz, 3PH
AMPS	14.8
TOTAL WATTS	6000
IN RUSH AMPS	87
PLUG TYPE	L16-20P
EER	10.0
COMPRESSOR	SCROLL
COMPRESSOR HP	5
COMPRESSOR LRA	52
EVAP CFM - HIGH	1950
EVAP MOTOR HP	1
COND CFM	2200
COND MOTOR HP	1
CONDENSATE REMOVAL	PUMP – 20' LIFT
REFRIGERANT CHARGE	80 oz R-410A
HEIGHT	51-3/4 in
WIDTH	27-1/2 in
DEPTH	39-1/2 in
NET WEIGHT	520 lb



HEATING & COOLING



SPECIFICATIONS SUBJECT TO CHANGE WITHOUT NOTICE

- ⓘ **Cooling Capacity** is total BTUH at 80°DB/67°WB return air 95°F Outdoor at high fan speed
- ⓘ **Heating Capacity** is total BTUH at 70°DB/60°WB Indoor, 47°DB/43°WB Outdoor
- ⓘ Dedicated Circuit and Time Delay fuses/circuit breakers are recommended
- ⓘ EER is determined at high fan speed, with condenser discharge air ducted into separate area
- ⓘ CFM with free discharge
- ⓘ Amps & Watts at 460 Volts

COOLING AMBIENT OPERATING RANGE 65° TO 105°

HEATING AMBIENT OPERATING RANGE 40° TO 85°

NOT APPROVED FOR OUTDOOR USE

Cooling and Heating done Right!!
OCEANAIRE

OCEANAIRE-INC.COM
OA-TS-2OACH6034-02112021

PRODUCT FEATURES

- OA SOLID STATE ELECTRONIC CONTROLLER
- OA AUTOMATIC MODE CHANGEOVER
- OA MANUAL OR AUTO 6-SPEED FAN CONTROL
- OA LARGE LED DISPLAY
- OA SWIVEL BALL BEARING CASTERS WITH LOCKING FRONTS
- OA CONDENSATE OVERFLOW ALERT
- OA HIGH PRESSURE SAFETY SWITCH
- OA THREE PHASE MONITOR
- OA WASHABLE ELECTROSTATIC AIR FILTERS

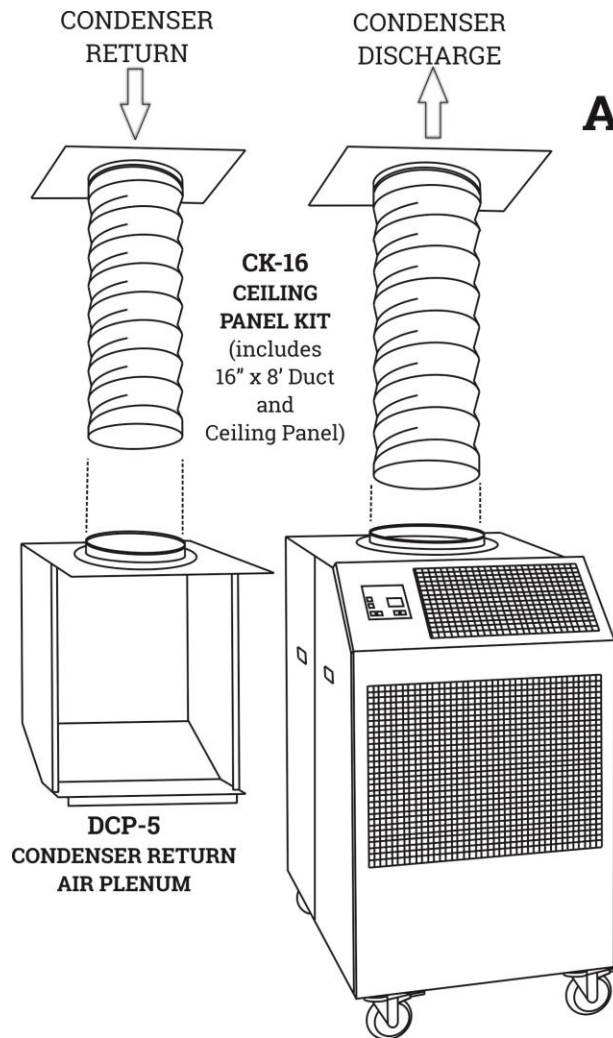

**CK-16
CEILING
PANEL KIT**
(includes
16" x 8' Duct
and
Ceiling Panel)

Optional ACCESSORIES

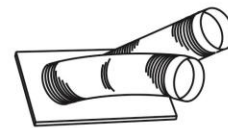

**2NK-3 (2 X 8")
NOZZLE KIT**
for Directional
Cooling/Heating

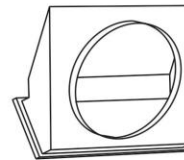

**2DDA-16
DISCHARGE
DUCT ADAPTER**
for Extended
Single Duct Length

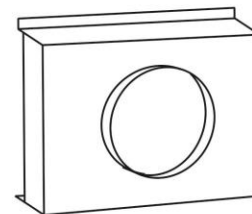

**DEP-16
EVAPORATOR RETURN
AIR PLENUM**

Cooling and Heating done Right!

OCEANAIRE