

# OCEANAIRE

**MODEL: PWC1811**  
**1.5 TON PORTABLE**  
**WATER-COOLED AIR CONDITIONER**

## TECHNICAL SPECIFICATIONS

<b>COOLING CAPACITY</b>	<b>18,000 BTUH</b>
VOLTAGE	115V, 60Hz, 1PH
AMPS	11.3
TOTAL WATTS	1300
IN RUSH AMPS	69
PLUG TYPE	5-15P, LCDI
EER	13.8
COMPRESSOR	ROTARY
COMPRESSOR HP	1-1/2
COMPRESSOR LRA	63
EVAP CFM - HIGH	600
EVAP MOTOR HP	1/8
CONDENSER WATER FLOW	
AT 60°F WATER IN	1.1 GPM
AT 85°F WATER IN	4.5 GPM
WATER LINE CONNECTIONS	
WATER IN	3/8 MF
WATER OUT	3/8 MF
DRAIN	3/8 MF
CONDENSATE REMOVAL	PUMP AUTOMATIC 20' VERTICAL LIFT
REFRIGERANT CHARGE	18 oz R-410A
HEIGHT	39-3/4 in
WIDTH	24-1/4 in
DEPTH	13 in
NET WEIGHT	155 lb



**WATER COOLED**



### SPECIFICATIONS SUBJECT TO CHANGE WITHOUT NOTICE

- ⓘ **Cooling Capacity** is total BTUH at 80°DB/67°WB return air with 85°EWT and 105°LWT
- ⓘ Dedicated Circuit and Time Delay fuses/circuit breakers are recommended
- ⓘ EER is determined at high fan speed
- ⓘ CFM with free discharge
- ⓘ Amps & Watts at 115 Volts

**COOLING AMBIENT**      **OPERATING RANGE 65° TO 105°**  
**NOT APPROVED FOR OUTDOOR USE**



*Cooling done Right!*  
**OCEANAIRE**

OCEANAIRE-INC.COM  
OA-TS-PWC1811-05012020

## PRODUCT FEATURES

- OA 24 VOLT NON-PROGRAMMABLE ELECTRONIC CONTROLLER
- OA SWIVEL BALL BEARING CASTERS WITH LOCKING FRONTS
- OA 2-SPEED FAN SWITCH
- OA INTERNAL CONDENSATE PUMP WITH OVERFLOW ALERT LIGHT
- OA AUTOMATIC WATER REGULATING VALVE
- OA HIGH PRESSURE SAFETY SWITCH
- OA WASHABLE ELECTROSTATIC AIR FILTER



## Optional ACCESSORIES

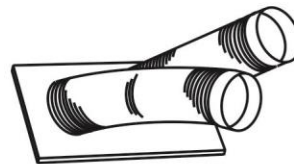
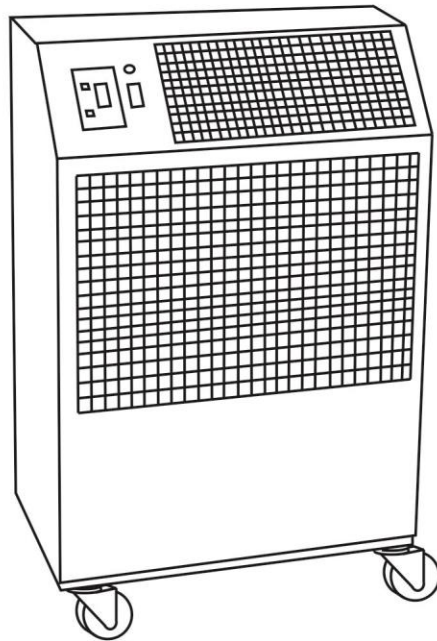

**NK-2 (2 x 6")**  
**NOZZLE KIT**  
for Directional  
Cooling/Heating

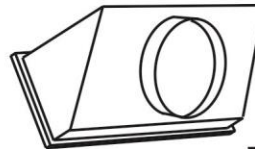

**DDA-10**  
**DISCHARGE**  
**DUCT ADAPTER**  
for Extended  
Single Duct Length

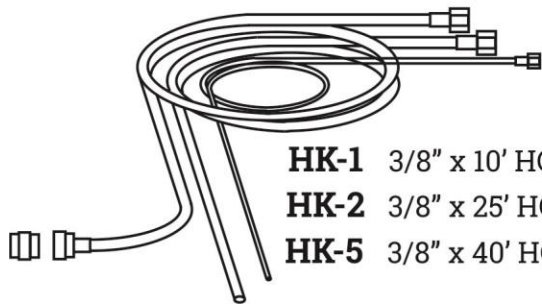

**HK-1** 3/8" x 10' HOSE KIT  
**HK-2** 3/8" x 25' HOSE KIT  
**HK-5** 3/8" x 40' HOSE KIT

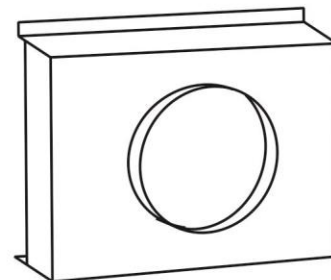

**2DEP-12**  
**EVAPORATOR RETURN**  
**AIR PLENUM**