

OCEANAIRE

MODEL: PWC3612
3 TON PORTABLE
WATER-COOLED AIR CONDITIONER

TECHNICAL SPECIFICATIONS

COOLING CAPACITY	36,100 BTUH
VOLTAGE	208-230V, 60Hz, 1PH
AMPS	12.0
TOTAL WATTS	2700
IN RUSH AMPS	100
PLUG TYPE	6-20P, LCDI
EER	13.4
COMPRESSOR	SCROLL
COMPRESSOR HP	3
COMPRESSOR LRA	83
EVAP CFM - HIGH	1200
EVAP MOTOR HP	1/3
CONDENSER WATER FLOW	
AT 60°F WATER IN	2.2 GPM
AT 85°F WATER IN	9 GPM
WATER LINE CONNECTIONS	
WATER IN	5/8 MF
WATER OUT	5/8 MF
DRAIN	3/8 MF
CONDENSATE REMOVAL	PUMP AUTOMATIC 20' VERTICAL LIFT
REFRIGERANT CHARGE	24 oz R-410A
HEIGHT	50-14 in
WIDTH	28-1/4 in
DEPTH	18 in
NET WEIGHT	275 lb



WATER COOLED



SPECIFICATIONS SUBJECT TO CHANGE WITHOUT NOTICE

- ⓘ **Cooling Capacity** is total BTUH at 80°DB/67°WB return air with 85°EWT and 105°LWT
- ⓘ Dedicated Circuit and Time Delay fuses/circuit breakers are recommended
- ⓘ EER is determined at high fan speed
- ⓘ CFM with free discharge
- ⓘ Amps & Watts at 208 Volts

COOLING AMBIENT **OPERATING RANGE 65° TO 105°**
NOT APPROVED FOR OUTDOOR USE



Cooling done Right!
OCEANAIRE

OCEANAIRE-INC.COM
OA-TS-PWC3612-05012020

PRODUCT FEATURES

- OA 24 VOLT NON-PROGRAMMABLE ELECTRONIC CONTROLLER
- OA SWIVEL BALL BEARING CASTERS WITH LOCKING FRONTS
- OA 2-SPEED FAN SWITCH
- OA INTERNAL CONDENSATE PUMP WITH OVERFLOW ALERT LIGHT
- OA AUTOMATIC WATER REGULATING VALVE
- OA HIGH PRESSURE SAFETY SWITCH
- OA WASHABLE ELECTROSTATIC AIR FILTER



Optional ACCESSORIES

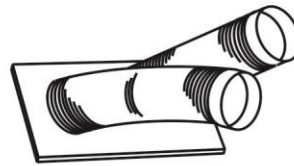
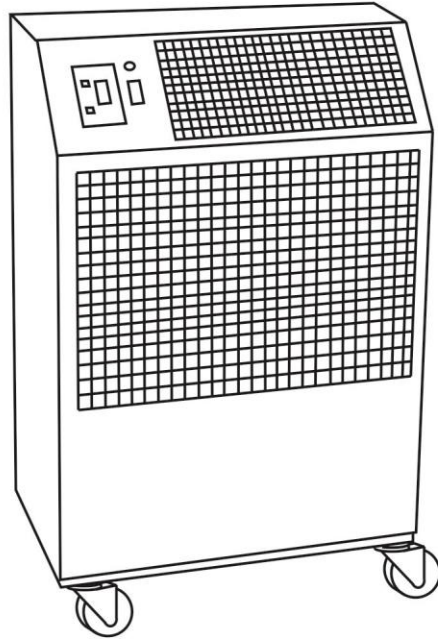

2NK-3 (2 x 8")
NOZZLE KIT
for Directional
Cooling/Heating

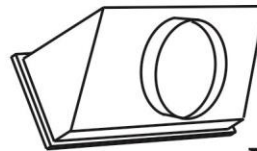

2DDA-16
DISCHARGE
DUCT ADAPTER
for Extended
Single Duct Length

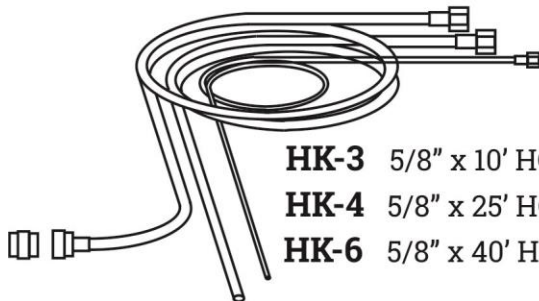

HK-3 5/8" x 10' HOSE KIT
HK-4 5/8" x 25' HOSE KIT
HK-6 5/8" x 40' HOSE KIT

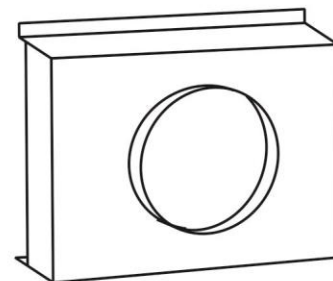

DEP-16
EVAPORATOR RETURN
AIR PLENUM

Cooling done Right!
OCEANAIRE