

OCEANAIRE

MODEL: PWC6012
5 TON PORTABLE
WATER COOLED AIR CONDITIONER

TECHNICAL SPECIFICATIONS

COOLING CAPACITY	60,100 BTUH
VOLTAGE	208-230V, 60Hz, 1PH
AMPS	23.7
TOTAL WATTS	5000
IN RUSH AMPS	165
PLUG TYPE	6-30P, LCDI
EER	12.0
COMPRESSOR	SCROLL
COMPRESSOR HP	5
COMPRESSOR LRA	158
EVAP CFM - HIGH	1950
EVAP MOTOR HP	1
COND WATER FLOW (GPM)	
AT 60°F INLET	3.8
AT 85°F INLET	15
WATER VALVE CONNECTION (INLET)	5/8 MF
WATER RETURN CONNECTION	5/8 MF
CONDENSATE REMOVAL	PUMP AUTOMATIC
20' VERTICAL LIFT	3/8 MF
REFRIGERANT CHARGE	52 oz R-410A
HEIGHT	51-1/2 in
WIDTH	45-1/4 in
DEPTH	29 in
NET WEIGHT	375 lb



WATER COOLED



SPECIFICATIONS SUBJECT TO CHANGE WITHOUT NOTICE

- OA **Cooling Capacity** is total BTUH at 80°DB/67°WB return air with 85°EWT and 105°LWT
- OA Dedicated Circuit and Time Delay fuses/circuit breakers are recommended
- OA EER is determined at high fan speed
- OA CFM with free discharge
- OA Amps & Watts at 208 Volts

COOLING AMBIENT **OPERATING RANGE 65° TO 105°**
NOT APPROVED FOR OUTDOOR USE



Cooling done Right!
OCEANAIRE

OCEANAIRE-INC.COM
OA-TS-PWC6012-03012020

OCEANAIRE

MODEL: PWC6012
5 TON PORTABLE
WATER COOLED AIR CONDITIONER

PRODUCT FEATURES

- OA 24 VOLT NON-PROGRAMMABLE ELECTRONIC THERMOSTAT
- OA SWIVEL BALL BEARING CASTERS WITH LOCKING FRONTS
- OA 2-SPEED FAN SWITCH
- OA INTERNAL CONDENSATE PUMP WITH OVERFLOW ALERT LIGHT
- OA AUTOMATIC WATER REGULATING VALVE
- OA HIGH PRESSURE SAFETY SWITCH
- OA WASHABLE ELECTROSTATIC AIR FILTER



ACCESSORIES

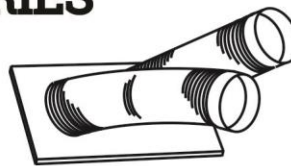
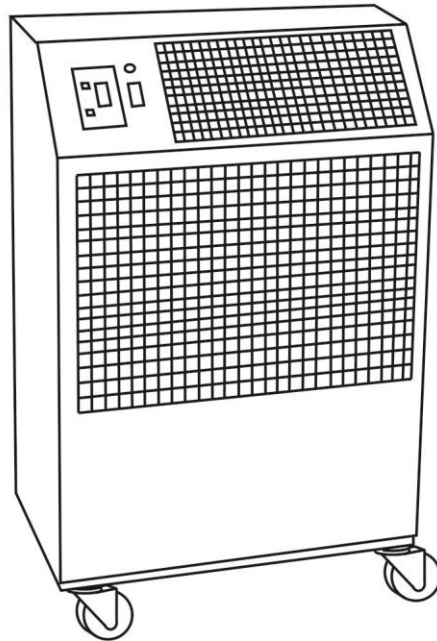

2NK-3 (2 x 8")
NOZZLE KIT
for Directional
Cooling/Heating

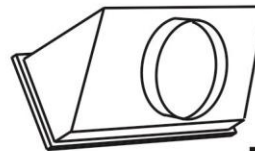

2DDA-16
DISCHARGE
DUCT ADAPTER
for Extended
Single Duct Length

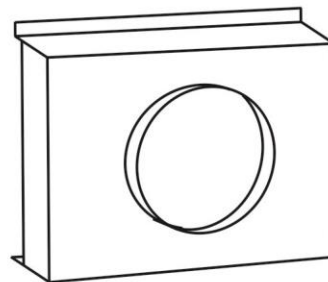

DEP-16
EVAPORATOR RETURN
AIR PLENUM

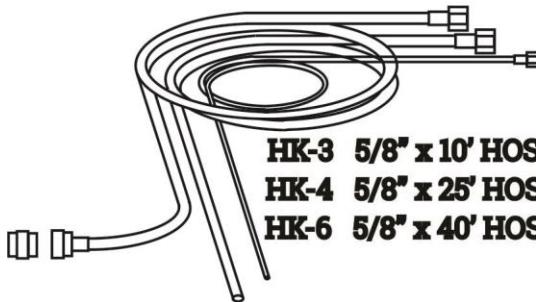

HK-3 5/8" x 10' HOSE KIT
HK-4 5/8" x 25' HOSE KIT
HK-6 5/8" x 40' HOSE KIT

Cooling done Right!

OCEANAIRE

OCEANAIRE-INC.COM
OA-TS-PWC6012-03012020