

OCEANAIRE

MODEL: PWC2412
2 TON PORTABLE
WATER COOLED AIR CONDITIONER

TECHNICAL SPECIFICATIONS

COOLING CAPACITY	23,950 BTUH
VOLTAGE	208-230V, 60Hz, 1PH
AMPS	9.9
TOTAL WATTS	2100
IN RUSH AMPS	55
PLUG TYPE	6-20P, LCDI
EER	11.4
COMPRESSOR	ROTARY
COMPRESSOR HP	2
COMPRESSOR LRA	48
EVAP CFM - HIGH	810
EVAP MOTOR HP	1/3
COND WATER FLOW (GPM)	
AT 60°F INLET	1.55
AT 85°F INLET	6
WATER VALVE CONNECTION (INLET)	3/8 MF
WATER RETURN CONNECTION	3/8 MF
CONDENSATE REMOVAL	PUMP AUTOMATIC
20' VERTICAL LIFT	3/8 MF
REFRIGERANT CHARGE	16 oz R-410A
HEIGHT	39-3/4 in
WIDTH	34-1/2 in
DEPTH	24-1/4 in
NET WEIGHT	170 lb



WATER COOLED



SPECIFICATIONS SUBJECT TO CHANGE WITHOUT NOTICE

- OA **Cooling Capacity** is total BTUH at 80°DB/67°WB return air with 85°EWT and 105°LWT
- OA Dedicated Circuit and Time Delay fuses/circuit breakers are recommended
- OA EER is determined at high fan speed
- OA CFM with free discharge
- OA Amps & Watts at 208 Volts

COOLING AMBIENT **OPERATING RANGE 65° TO 105°**
NOT APPROVED FOR OUTDOOR USE



Cooling done Right!

OCEANAIRE

OCEANAIRE-INC.COM
OA-TS-PWC2412-03012020

OCEANAIRE

MODEL: PWC2412
2 TON PORTABLE
WATER COOLED AIR CONDITIONER

PRODUCT FEATURES

- OA 24 VOLT NON-PROGRAMMABLE ELECTRONIC THERMOSTAT
- OA SWIVEL BALL BEARING CASTERS WITH LOCKING FRONTS
- OA 2-SPEED FAN SWITCH
- OA INTERNAL CONDENSATE PUMP WITH OVERFLOW ALERT LIGHT
- OA AUTOMATIC WATER REGULATING VALVE
- OA HIGH PRESSURE SAFETY SWITCH
- OA WASHABLE ELECTROSTATIC AIR FILTER



ACCESSORIES

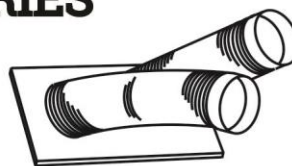
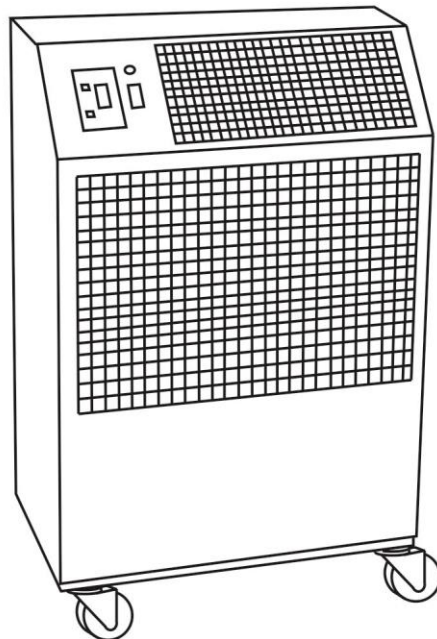

NK-2 (2 x 6")
NOZZLE KIT
for Directional
Cooling/Heating

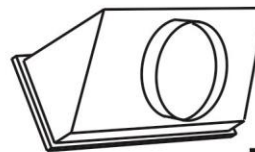

DDA-10
DISCHARGE
DUCT ADAPTER
for Extended
Single Duct Length

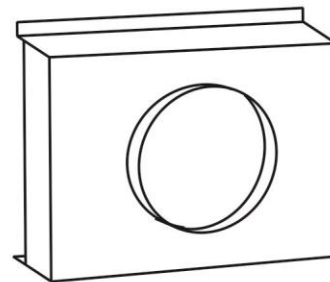

2DEP-12
EVAPORATOR RETURN
AIR PLENUM

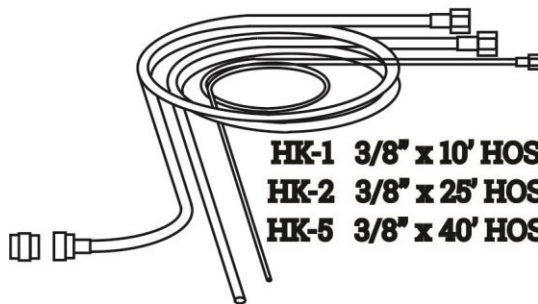

HK-1 3/8" x 10' HOSE KIT
HK-2 3/8" x 25' HOSE KIT
HK-5 3/8" x 40' HOSE KIT

Cooling done Right!

OCEANAIRE

OCEANAIRE-INC.COM
OA-TS-PWC2412-03012020