

OCEANAIRE

MODEL: 2OACH1811
1.5 TON PORTABLE HEAT PUMP

TECHNICAL SPECIFICATIONS

COOLING CAPACITY	16,800 BTUH
HEATING CAPACITY	15,000 BTUH
VOLTAGE	115V, 60Hz, 1PH
AMPS	14.1
TOTAL WATTS	1670
IN RUSH AMPS	75
PLUG TYPE	5-20P, LCDI
EER	10.0
COMPRESSOR	ROTARY
COMPRESSOR HP	1-1/2
COMPRESSOR LRA	63
EVAP CFM - HIGH	600
EVAP MOTOR HP	1/8
COND CFM	930
COND MOTOR HP	1/8
CONDENSATE TANK (Pump Optional)	5 GALLON
REFRIGERANT CHARGE	40 oz R-410A
HEIGHT	45-3/4 in
WIDTH	24 in
DEPTH	30 in
NET WEIGHT	260 lb



HEATING & COOLING



SPECIFICATIONS SUBJECT TO CHANGE WITHOUT NOTICE

- OA **Cooling Capacity** is total BTUH at 80°DB/67°WB return air, 95°F Outdoor at high fan speed
- OA **Heating Capacity** is total BTUH at 70°DB/60°WB indoor, 47°DB/43°WB Outdoor
- OA Dedicated Circuit and Time Delay fuses/circuit breakers are recommended
- OA EER is determined at high fan speed, with condenser discharge air ducted into separate area
- OA CFM with free discharge
- OA Amps & Watts at 115 Volts

COOLING AMBIENT OPERATING RANGE 65° TO 105°

HEATING AMBIENT OPERATING RANGE 40° TO 85°

NOT APPROVED FOR OUTDOOR USE



Cooling and Heating done Right!

OCEANAIRE

OCEANAIRE-INC.COM
OA-TS-2OACH1811-03012020

OCEANAIRE

MODEL: 2OACH1811
1.5 TON PORTABLE HEAT PUMP

PRODUCT FEATURES

- OA SOLID STATE ELECTRONIC CONTROLLER
- OA AUTOMATIC MODE CHANGEOVER
- OA MANUAL OR AUTO 6-SPEED FAN CONTROL
- OA LARGE LED DISPLAY
- OA SWIVEL BALL BEARING CASTERS WITH LOCKING FRONTS
- OA CONDENSATE OVERFLOW ALERT
- OA HIGH PRESSURE SAFETY SWITCH
- OA WASHABLE ELECTROSTATIC AIR FILTERS

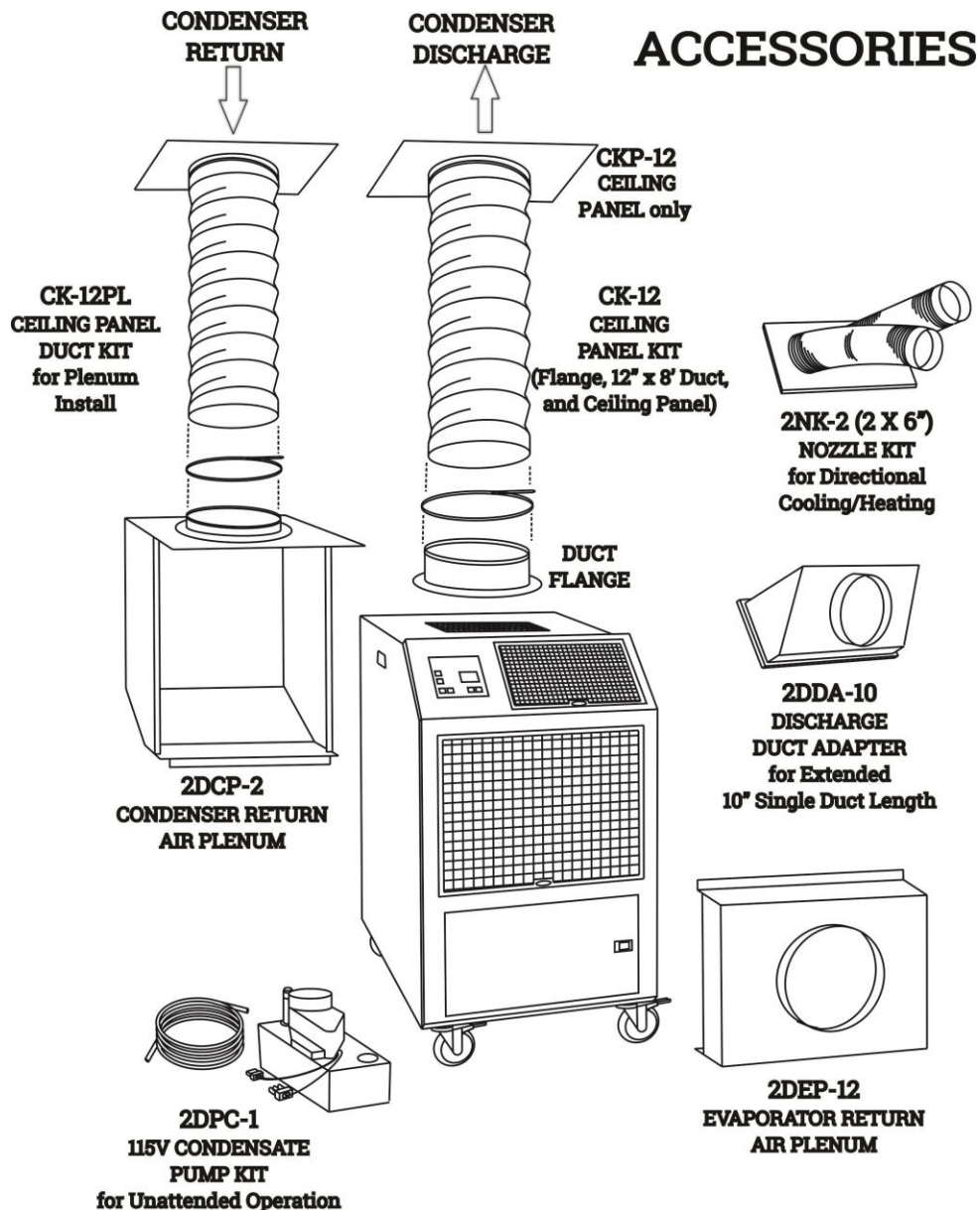

OCEANAIRE

OCEANAIRE-INC.COM
OA-TS-2OACH1811-03012020