

OCEANAIRE

MODEL: 2OAC3632
3 TON DELUXE PORTABLE
AIR CONDITIONERS

TECHNICAL SPECIFICATIONS

COOLING CAPACITY	36,050 BTUH
VOLTAGE	208-230V, 60Hz, 3PH
AMPS	17.2
TOTAL WATTS	3620
IN RUSH AMPS	93
PLUG TYPE	L15-30P
EER	10.0
COMPRESSOR	Scroll
COMPRESSOR HP	3
COMPRESSOR LRA	77
EVAP CFM - HIGH	1200
EVAP MOTOR HP	1/3
COND CFM	1390
COND MOTOR HP	1
CONDENSATE TANK (Pump Optional)	5 GALLON
REFRIGERANT CHARGE	66 oz R-410A
HEIGHT	50-1/4 in
WIDTH	27-1/2 in
DEPTH	35 in
NET WEIGHT	365 lbs



AIR COOLED



SPECIFICATIONS SUBJECT TO CHANGE WITHOUT NOTICE

- ⓘ **Cooling Capacity** is total BTUH at 80°DB/67°WB return air, 95°F Outdoor at high fan speed
- ⓘ Dedicated Circuit and Time Delay fuses/circuit breakers are recommended
- ⓘ EER is determined at high fan speed, with condenser discharge air ducted into separate area
- ⓘ CFM with free discharge
- ⓘ Amps & Watts at 208 Volts

COOLING AMBIENT OPERATING RANGE 65° TO 105°

NOT APPROVED FOR OUTDOOR USE



Cooling done Right!

OCEANAIRE

OCEANAIRE-INC.COM
OA-TS-2OAC3632-03012020

OCEANAIRE

MODEL: 20AC3632
3 TON DELUXE PORTABLE
AIR CONDITIONERS

PRODUCT FEATURES

- OA SOLID STATE ELECTRONIC CONTROLLER
- OA MANUAL OR AUTO 6-SPEED FAN CONTROL
- OA LARGE LED DISPLAY
- OA SWIVEL BALL BEARING CASTERS WITH LOCKING FRONTS
- OA CONDENSATE OVERFLOW ALERT
- OA HIGH PRESSURE SAFETY SWITCH
- OA THREE PHASE MONITOR
- OA WASHABLE ELECTROSTATIC AIR FILTERS

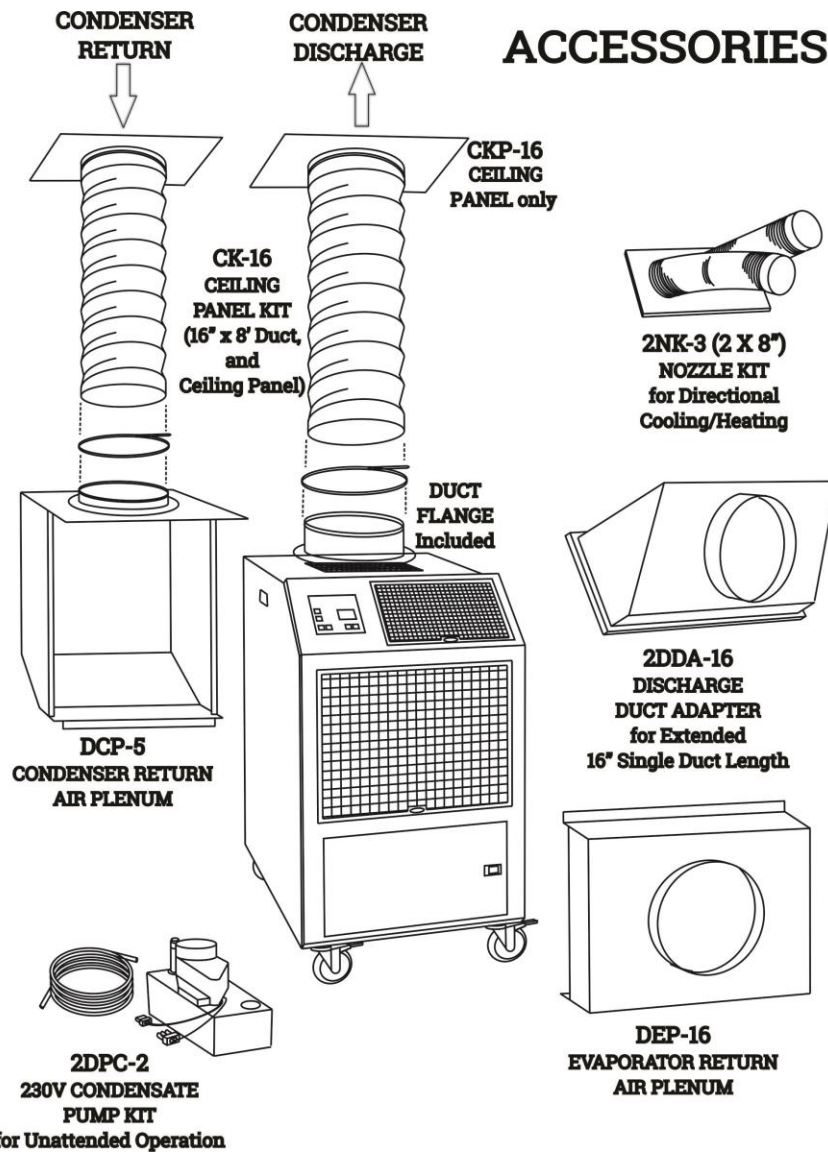

Cooling done Right!

OCEANAIRE

OCEANAIRE-INC.COM
OA-TS-20AC3632-03012020